

The Effect of Magnetic Abrasive Finishing on the Flat Surface for Ferromagnetic and non-Ferromagnetic materials

Ali H. Kadhum*

Yahya M. Hamad

Nazar Kais M. Naif

Baghdad University/Al-Khawarizmi

College of Engineering /Manufacturing Operations Department

Al-Jadria, Baghdad.

*E-mail: kadhuali59@yahoo.com

Abstract

Magnetic Abrasive Finishing (MAF) is an advanced finishing method, which improves the quality of surfaces and performance of the products. The finishing technology for flat surfaces by MAF method is very economical in manufacturing fields an electromagnetic inductor was designed and manufactured for flat surface finishing formed in vertical milling machine. Magnetic abrasive powder was also produced under controlled condition. There are various parameters, such as the coil current, working gap, the volume of powder portion and feed rate, that are known to have a large impact on surface quality. This paper describes how Taguchi design of experiments is applied to find out important parameters influencing the surface quality generated during MAF method. In the experimental part, two types of materials from non-ferromagnetic and ferromagnetic (Aluminum alloy 7020 and stainless Steel 410 respectively) were considered with different parameters. Regressions models based on statistical-mathematical approach were obtained by using SPSS software for two materials.

Keywords: Magnetic Abrasive Finishing (MAF), ferromagnetic materials, non-ferromagnetic materials, surface roughness, SPSS software, Taguchi experimental design, magnetic abrasive powder, manufacturing electromagnetic inductor, flat surface,

Introduction:

A magnetic abrasive finishing (MAF) method is defined as a process in which the material is removed by flexible magnetic abrasive brush. The magnetic abrasive particles join each other by magnetic fields forming brush between magnetic pole and work piece. Brush can be controlled by the electric current supplied [1-10]. This method may be applied for finishing of different shape surfaces and different worked materials (i.e. non-ferrous alloy, ferrous, semiconductors, quartz...) that cannot be processed by the conventional processes efficiently and economically [8].

Magnetic abrasive finishing was used only for surface finishing [5, 11]. The quality of the surface of finished parts depends strongly on the surface roughness (R_a) and a physical-mechanical characteristic which permits judgment of the formed micro-relief state. Among these characteristic, R_a play a key role, because the roughness of working surfaces greatly influences the longevity of parts [12]. The surface roughness left by the MAF operation depends both on the type of material being finishing and on MAF method parameters. There are various parameters such as the coil current, working gap, feed rate and the volume of powder that are known to have a large impact on surface quality [7,9,11,13]. Therefore, it is important to gain better understanding how the MAF process affects the functional behavior of the flat surface. This study first attempts to develop a surface finishing technique for flat surfaces, of ferromagnetic materials such as stainless steel and non-ferromagnetic materials such as aluminum alloys. The characteristic equations can be obtained from Taguchi experiment method, which enables to predict the surface quality.

The aims of this research are as follows:

- Design and manufacture magnetic abrasive finishing device.
- To propose a relationship between surface roughness, and the parameters of MAF.
- To find proper abrasive conditions for MAF method of non-ferromagnetic and ferromagnetic materials (Aluminum alloy 7020 and stainless steel 410 respectively) for flat surfaces.

Designing of electromagnetic inductor

According to the characteristic of magnetic abrasive finishing behavior in the process, experimental setup of the finishing experimental device which was designed and made in machining laboratory at Baghdad University is shown in Fig 1. The device consists of electromagnetic inductor 1, D.C power supply 2, slip rings 3, work piece 4, and table 5.

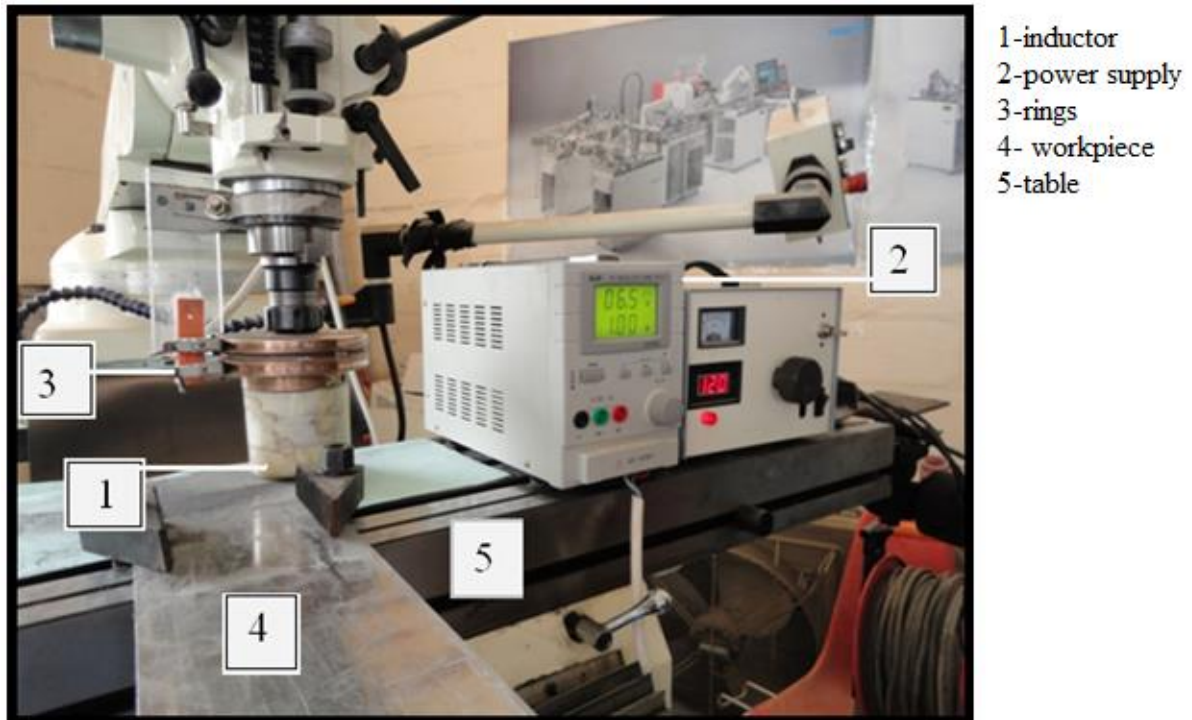

Figure 1.A photograph of the magnetic abrasive finishing device.

Figure 2 shows a schematic diagram of electromagnetic inductor and brush (6) drawn to understand the mechanism of material removal in the MAF process. A fixture (8) with work piece (7) is placed on the table of the machine (9). The body of inductor was fixed on the milling machine spindle (1) by the cone shank. The coil (4) is located inside the inductor body, and collected rings (2) are placed on the top plane of the body.

They are intended to connect the coil with a constant current through D.C. power supply. The working gap between the pole (5) and worked surface of a work piece are filled by magnetic

abrasive particles (6) in time of finishing. When the inductor rotates, the brush also rotates concomitantly with the same rotational speed of the spindle, the machine table together with fixture and work piece has to feed, resulting in the relative motion between the brush and work piece leading to abrasive finishing of the surface. The material of the iron core (3) is low carbon steel, the cross-section area of the iron core is $A = (14 \text{ cm}^2)$, the length of the iron core is 75 mm, the diameter of the copper wire of the magnetic coil is 1 mm and the number of turns is 1400.

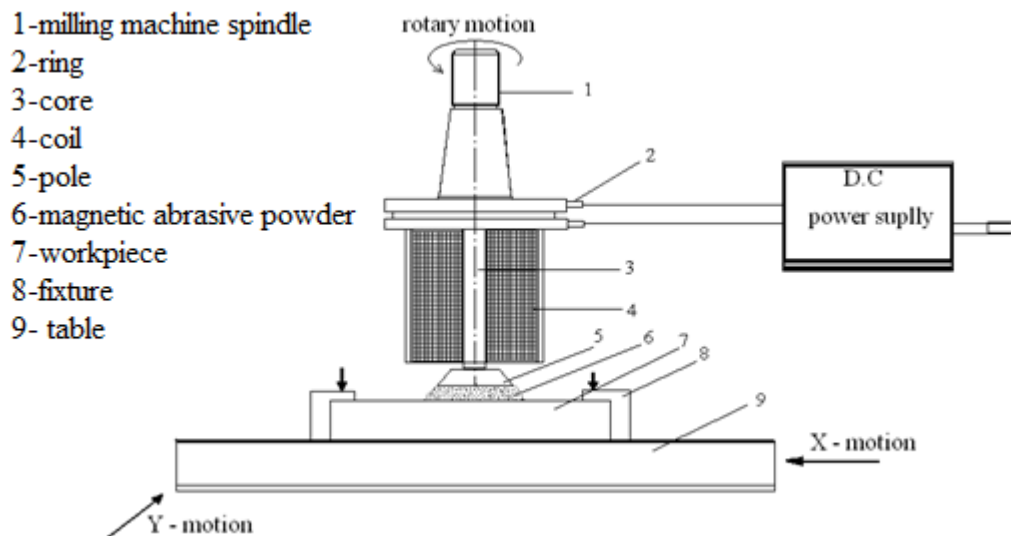

Figure (2): Schematic diagrams of electromagnetic inductor and brush.

Materials and tests condition

A series of experiments were made to finish two kinds of specimens' materials, one is non-ferromagnetic, Al 7020 alloy, whose chemical composition in weight (%), is Si = 0.7 - 1.3, Fe = 0.5max, Cu = 0.1max, Mn = 0.4 - 1.0, Cr = 0.25max, Mg= 0.06 - 1.2, Zn = 0.2max, Ti = 0.1max, others = 0.05max., the dimensions of flat plate are length 100mm, width 50mm, thickness 8mm. The average of measured roughness of the surface before operation is $R_a = 0.3 - 0.5 \mu\text{m}$. The second material was ferromagnetic stainless steel 410 whose chemical composition in weight (%) is C = 0.15, Mn = 1.00, P = 0.04, S = 0.03, SI = 1.00, Cr = 11.5 - 13.5, the dimensions of plate are length 120mm, width 60mm, thickness 2mm. The average of measured roughness before finishing $R_a = 0.4 - 0.5 \mu\text{m}$. The abrasive powder, which was produced in the same machining laboratory, consisted of silicon carbide SiC, mesh № 250 μm ,

SiC (70%) and ferromagnetic iron particles, mesh № 300 μm , Fe (30%).

Experimental of MAF setup

Figure 3 shows a photograph of actual setup used during experimentation. In this process, the magnetic flux density of (0–0.4) T is used in the working gap. The magnetic flux density in the working gap is varied by changing the input current to the electromagnet, on the supply of current to the magnet, the work piece gets magnetized. During the design of the setup, using the Taguchi experimental design, the parameters that have been considered are the effect of the coil current (1 – 3) A, working gap (1.5 – 2.5) mm, the volume of powder portion (2 – 4) cm^3 and feed rate (100 – 140) mm/min, at constant cutting speed. The experimental data was collected using the Taguchi experimental design.

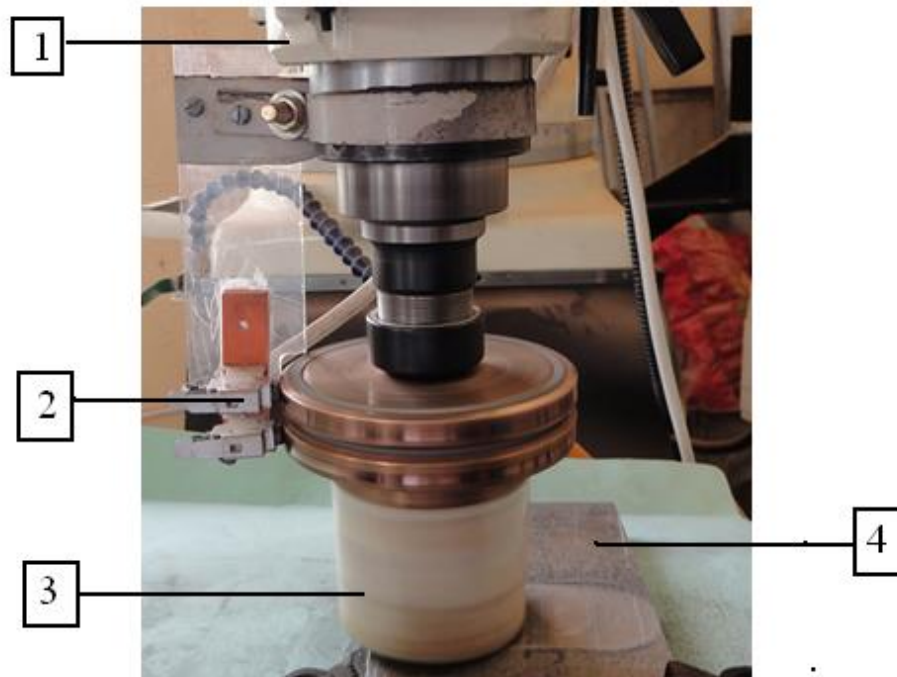

Figure (3): Photograph of the external view MAF setup: (1) column of milling machine, (2) Slip ring, (3) Electromagnetic inductor (4) work piece

Experimental design and operating parameters

In the present work, the experiments have been designed using highly fractional factorial experimental design (Taguchi's orthogonal array) to determine the influence of various factors on the response (surface roughness).

The Taguchi experimental design involved three stages. First, a Taguchi orthogonal array L9 was used to ensure consideration of the most significant factors and levels, therefore, optimizing the condition of MAF. This

investigation considered four factors (working gap, volume of powder, feed rate, and coil current). An orthogonal array (OA) L9 (3^4) for a three-level factor is used in the present investigation. This array has nine rows and each row represents a trial condition with factor levels indicated by the numbers in the row. The vertical columns correspond to the factors specified in the study and each contains three levels 1, three levels 2, and three levels 3 conditions (a total of nine conditions) for the factor assigned to the column. Each column (factor) has nine possible

combinations: (1, 1), (1, 2), (1, 3), (2, 1), (2, 2), (2, 3), (3, 1), (3, 2), and (3, 3). Note that any two columns of an L9 (3⁴) not only have these possibilities but also have the same number of times of these possible combinations. Thus, all four columns of an L9 (3⁴) are said to be balanced, orthogonal or statistically independent of each other [14]. The process parameters listed in Table 1 have been selected based on the earlier studies [13, 15, and 16] and setup constraints. Secondly, after the data collection, SPSS was analyzed using statistical software to identify the significance of the parameters considered in this study. Finally, the optimal operation condition was generated and the confirmatory tests were conducted.

Table (1): Operating parameters of MAF

Parameter	Rang	symbol
Working gap(mm)	1.5 – 2.5	X ₁
Volume of powder(cm ³)	2.0 – 4.0	X ₂
Feed rate(mm/min)	100 – 140	X ₃
Coil current(A)	1 – 3	X ₄

Details of the experimental design and approach for aluminum alloy and stainless steel are given in Table 2 and Table 3. The factors under consideration, namely working gap (mm), volume of powder (cm³), feed rate(mm/min) and coil current (A), are placed in the columns (X1, X2,X3, and X4, respectively) of the OA L9 (3⁴). The outputs (change in surface roughness ΔRa, and microrelif) are the test results.

Table (2): Experimental design (L9 OA) and results for aluminum alloy 7020

№	X1	X2	X3	X4	ΔRa1 before	ΔRa2 after	ΔRa(μm)
1	1.5	2	100	1	0.44	0.38	0.06
2	1.5	3	120	2	0.36	0.24	0.12
3	1.5	4	140	3	0.32	0.30	0.02
4	2.0	2	120	3	0.36	0.26	0.10
5	2.0	3	140	2	0.30	0.27	0.03
6	2.0	4	100	1	0.35	0.20	0.15
7	2.5	2	140	2	0.31	0.30	0.01
8	2.5	3	100	3	0.40	0.32	0.08
9	2.5	4	120	1	0.40	0.30	0.10

Table (3).Experimental design (L9 OA) and results for stainless steel 410

№	X1	X2	X3	X4	ΔRa1/ before	ΔRa2/after	ΔRa (μm)
1	1.5	2	100	1	0.44	0.16	0.28
2	1.5	3	120	2	0.45	0.18	0.27
3	1.5	4	140	3	0.40	0.22	0.18
4	2.0	2	120	3	0.39	0.26	0.13
5	2.0	3	140	2	0.40	0.20	0.20
6	2.0	4	100	1	0.39	0.24	0.15
7	2.5	2	140	2	0.42	0.28	0.14
8	2.5	3	100	3	0.45	0.19	0.26
9	2.5	4	120	1	0.50	0.21	0.29

Experimental procedures

The experiments were executed according to the following procedures:-

1. The workpiece is fixed in the slot of the fixture in such a way that center of the workpiece coincides with the center of the pole of the magnet. The required gap between the flat-faced pole and workpiece is set with the help of slip gauges. Again after setting the gap, both the flat-faced magnet and workpiece are checked with reference to the table of the machine. The magnetic abrasive particles are prepared just before the start of each experiment. The test specimens were finished by MAF in dry condition (without lubricating fluids). At the end of each experiment, the fixture and workpiece are taken out from the MAF setup. After cleaning properly, the change in surface roughness value (ΔRa) is determined by measuring Ra (center line average value) before and after magnetic abrasive finishing, at five different places from the center of the workpiece. The difference in these two Ra values (before and after MAF) at the same location is called ΔRa.

2. The surface roughness Ra (arithmetic average) was measured in surface roughness instrument (PROFILOMETER laboratory roughness measuring device) with suitable cut off length 0.8.

3. The measurement has been done by moving the stylus in the same area perpendicular to the lays obtained in the process.

4. Surface roughness tests were executed five times for each sample before and after finishing, then the mean value of ΔRa1 and ΔRa2 was obtained. The change between the two values ΔRa for all samples was recorded. The experiments were conducted according to the Taguchi matrix.

5. Scanning micrographs of surface microrelief for aluminum alloy 7020 and stainless steel 410 before and after MAF (× 1250) were used to show topography of surface.

Results and discussion

Table 2 and Table 3 summarizes the experimental results showing the variation of the change in surface roughness (ΔRa) at five different locations but equidistant from the center of the workpiece. Various finishing conditions (№ 1–9) at three levels of working gap, volume of powder, feed rate, and current are also given in Table 2 and Table3. Using these data, the SPSS-statistical software has been employed to analyze the experimental findings. The following linear regression models have been obtained:

For aluminum alloy 7020

$$\Delta Ra_{(AL)} = 2.63 - 0.033 X_1 + 0.161 X_2 - 0.0186 X_3 - 0.032 X_4 \dots(1)$$

For stainless steel 410

$$\Delta Ra_{(ST)} = 3.81 - 0.133 X_1 + 0.090 X_2 - 0.0115 X_3 - 0.158 X_4 \dots(2)$$

The variance ratio (F) is more than the standard value of F at 95% confidence interval ($\alpha = 0.05$) [16]. The variance ratio (F) value is used to measure the significance of the regression. These equations (1) and (2) can be used to predict the response in the MAF process. From the ANOVA, the significant factors affecting surface roughness for aluminum alloy 7020 were volume of powder, working gap, current, and feed rate,

respectively. The contributions of each factor were $X_2 = 46.35\%$ for volume of powder, $X_1 = 36.8\%$ for working gap, $X_4 = 10.46\%$ for current, and $X_3 = 4.3\%$ for feed rate. The larger the volume of powder between the magnetic pole and workpiece, the stronger the brush will be. At the same time, the surface roughness will be affected, and therefore, it is important to adjust the volume of powder and working gap properly, in order to obtain a good quality surface finish.

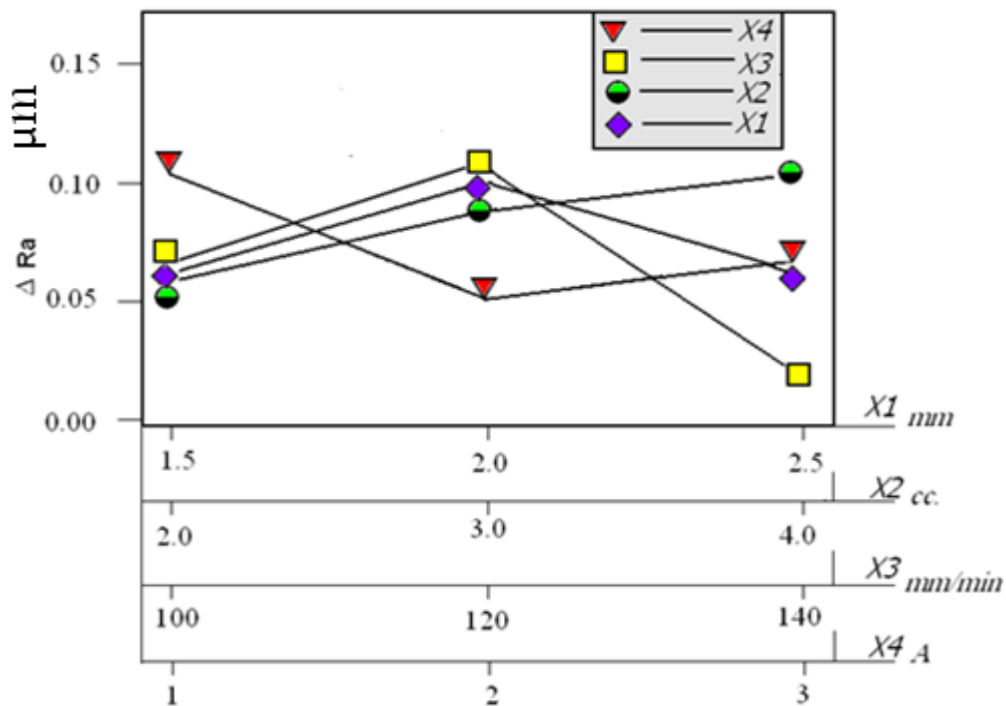

Figure (4): Main effects of MAF parameters on the change of roughness for aluminum alloy 7020

Figure 4 shows the effects of MAF parameters on the change in surface roughness for aluminum alloy 7020. Since larger ΔRa of the finished surface is desirable, it is concluded from the main effects in Fig.4 that the optimum condition for the parameters are working gap $X_1 = 2$ mm, volume of powder $X_2 = 4\text{cm}^3$, feed rate $X_3 = 120$ mm/min, and the current $X_4 = 1$ A. These values put the brush in the best form, and give the best elasticity for the brush resulting in reduced surface roughness.

From the ANOVA, the significant parameters affecting surface roughness for stainless steel 410 were the current, working gap, volume of powder, and feed rate: The contributions of each parameter were 37.8% for current, 36.1% for working gap, 21.0% for volume of powder, and 5.1% for feed rate. More current in the working zone, will give density to the brush. At the same time, surface roughness will be affected, and it is important to adjust the current and working gap properly, in order to obtain a good quality surface finish.

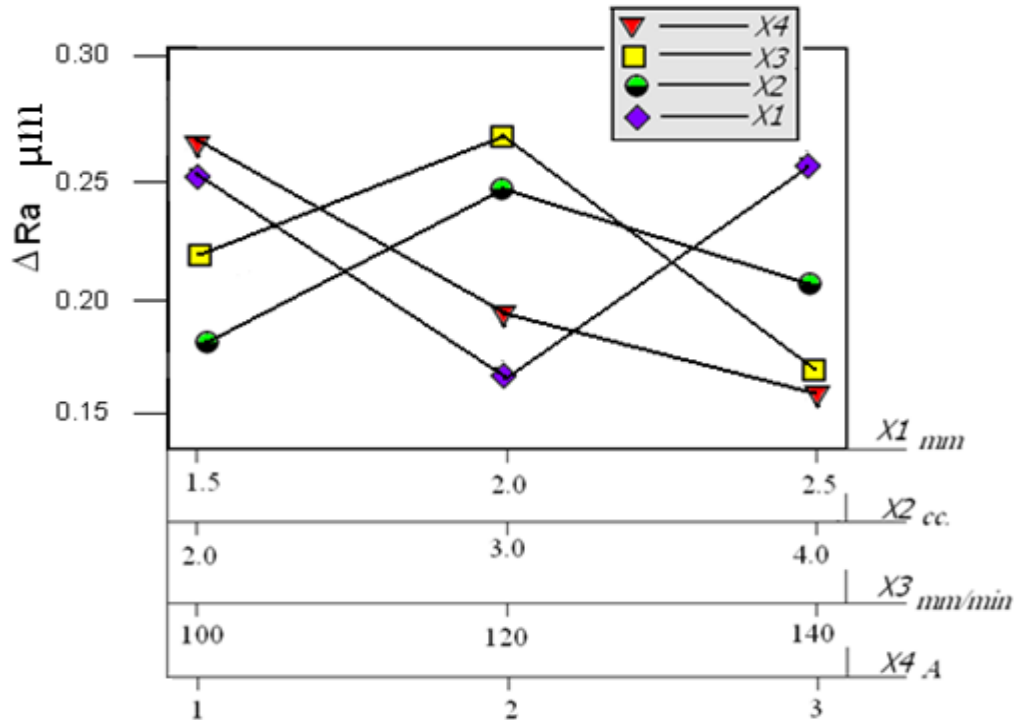

Figure (5): Main effects of MAF parameter on the change of roughness for stainless steel 410

Figure 5 shows the effects of MAF parameters on the change in roughness (ΔRa) for stainless steel 410. The optimum condition for the parameters in this alloy are current $X_4 = 1A$, working gap $X_1 = 2.5$ mm, volume of powder $X_2 = 3$ cm³ and the feed rate $X_3 = 120$ mm/min. The optimum values for current 1A and feed rate 120 mm/min are the same as in aluminum alloy 7020. When the working gap was increased (from 1.5 to 2.5 mm), and the magnetic field strength decreased, which simultaneously decreased the density of the magnetic brush, a shorter and less stiff magnetic brush and a smaller pressure on the workpiece will be created. Then, the workpiece surface can be finished ideally in the ferromagnetic materials (stainless steel 410), and the surface roughness becomes good. Thus, a working gap (2.5 mm) of the Taguchi experimental design will yield the optimum surface finish in this study.

The volume of powder for ferromagnetic materials does not have the characteristic of larger-the-better because the extra abrasives cannot produce the stirring function and decrease the finishing function of the magnetic brush. Simultaneously, the powder becomes a condensed block against the surface of the workpiece with a hard contact and retain large amounts of scratches, making the surface finish unacceptable. On the other hand, a small mass of abrasives can cause an insufficient filling in the working zone, and a dysfunction of the magnetic brush in which it cannot reach a good surface finish. In this study,

we should choose the best volume of powder which gives the best form for brush in order to improve the surface finish. Table 4 shows the difference between the optimum parameters for ferromagnetic and non-ferromagnetic materials.

Table (4): The difference between parameters of MAF for ferromagnetic and non-ferromagnetic materials

Parameters	Optimum values for non-ferromagnetic material	Optimum values for ferromagnetic material
X_1 , Working gap(mm)	2.0	2.5
X_2 , Volume of powder(cm ³)	4.0	3.0
X_3 , Feed rate(mm/min)	120	120
X_4 , Coil current(A)	1.0	1.0

The MAF regression model, using Taguchi method, can be used to analyze the effects of the selected process parameters on the surface roughness. In order to determine the interaction effect of the finishing process parameters on Ra, figure 6 shows the interaction of the two parameters which have the largest impact on the finishing quality for Aluminum alloy (the volume of powder and working gap), while the third and fourth parameters are kept at constant values, $X_3 = 120$ mm/min and $X_4 = 1A$ for both materials.

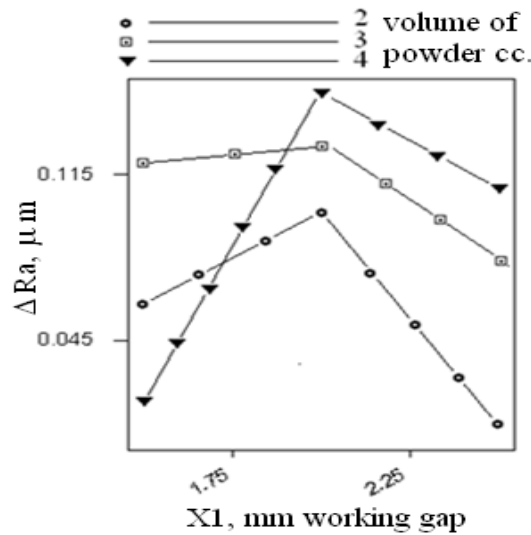

Figure (6): The interaction effects of working gap for different volume of powder on the ΔRa for aluminum alloy 7020 at constant values, $X_3 = 120$ mm/min and $X_4 = 1$ A

It can be observed from figure 6 for non-ferromagnetic material that, ΔRa for a given working gap (after $X_1 = 2.0$ mm), the surface roughness sharply increases with the increase in the volume of powder at constant feed rate and current. The trend of the curves is the same for different volume of powder values. The change in the roughness (ΔRa) increases with increase in the working gap to 2mm, after that the curve decreases because of the fact that higher working

gap need more powder, and therefore affects the form of brush at a specified gap. Figure 7(a, b) shows different form of brush depending upon the volume of powder and working gap, figure 7(a) shows the optimum form of brush at 4 cm^3 , where the form of brush is completed, figure 7(b) shows the brush at volume of powder 2 cm^3 , at the same working gap and current where the form of brush is not completed.



(a)

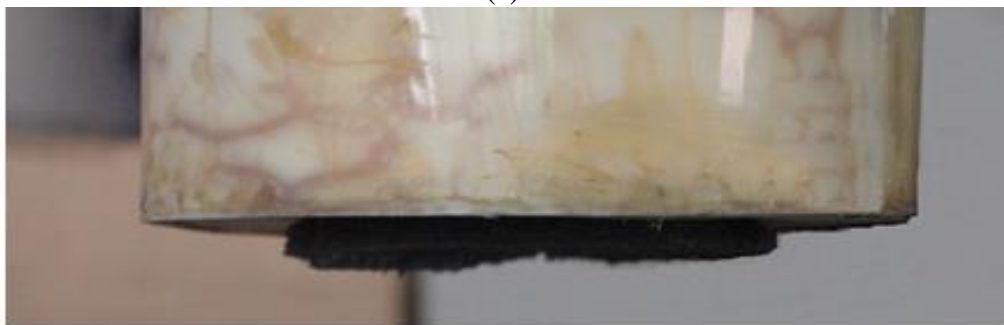

(b)

Figure (7): A photograph of flexible magnetic abrasive brush of different electromagnetic brush forms (a) The optimum form for AL 7020, at volume of powder 4 cm^3 with working gap 2mm, and current 1A (b) at volume of powder 2 cm^3 at the same of working gap and current.

Figure 8 shows the interaction of the two parameters which have the largest impact on the finishing quality for stainless steel 410 (the current and working gap), while the volume of powder and feed rate parameters are kept at constant value ($X_3 = 120 \text{ mm/min}$ and $X_4 = 1 \text{ A}$ for both materials). For ferromagnetic material, the surface roughness for a given working gap(to two

$X_1 = 2 \text{ mm}$) has a tendency to improve with the decrease in the coil current. Machining ferromagnetic workpeice in the working zone brings additional magnetic pole in the gap which helps in the creation of the brush see (Figure 9). Therefore, the best finishing for ferromagnetic material needs lower value of current and maximum value of working gap

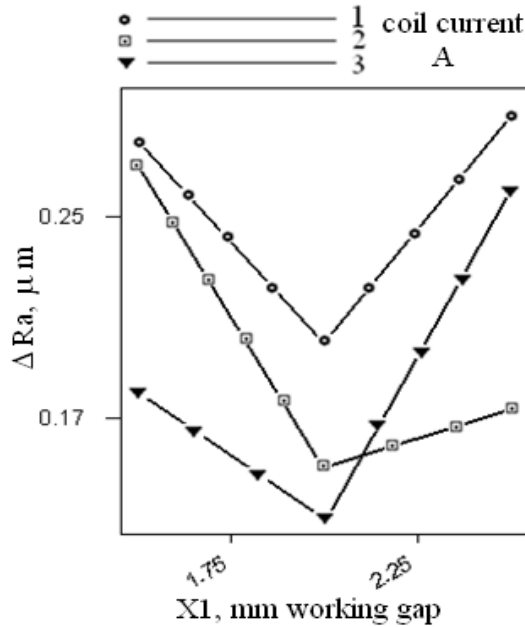

Figure (8): The interaction effects of MAF parameters on the ΔRa for Stainless steel 410 at constant value ($X_3 = 120 \text{ mm/min}$ and $X_2 = 3 \text{ cm}^3$)

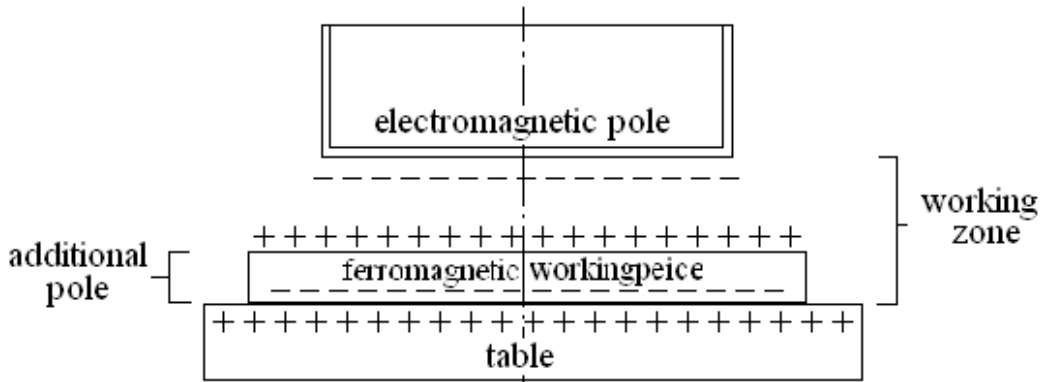

Figure (9): The creation of additional pole

Figures 10, 11, show micrographs of finished surface by the MAF method. Topography of microrelief formed after MAF (fig.10b, and 11b) shows reduction in machining traces, and in the frequency of microscratches and possesses more

smoothing tops and bottoms of microuneveness, in comparison with before MAF(Fig.10a and 11a). It should be also noted that the full absence of charging traces and other places of pitting for stainless steel 410.

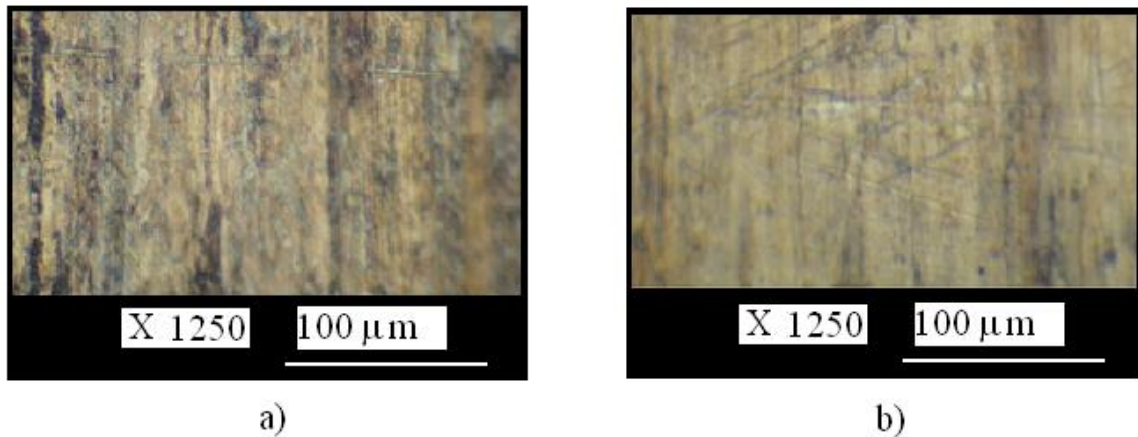

Figure (10): Scanning micrograph of topography of surface microrelief for aluminum alloy 7020 formed: a) before MAF b) after MAF. At working gap = 2mm, volume of powder = 4 cm³, feed rate =100 mm/min, the coil current = 2A.

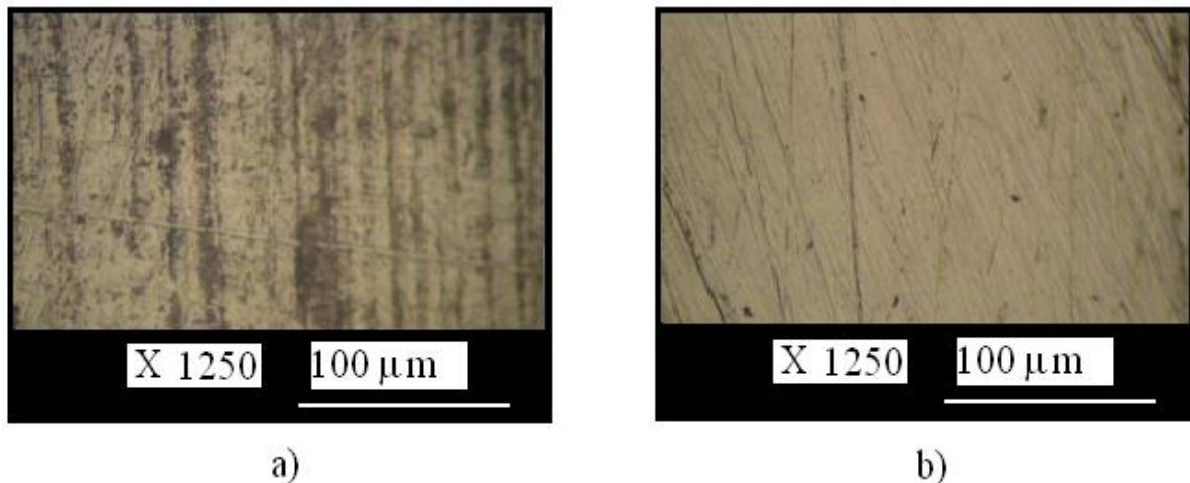

Figure (11): Scanning micrograph of topography of surface microrelief for stainless steel 410 formed: a) before MAF b) after MAF. At working gap = 2.5 mm, volume of powder = 3cm³, feed rate =100 mm/min, the coil current = 3 A.

Conclusions

The following conclusions were made based on the results of the implemented research:

1. Magnetic inductor and device for finishing flat surface is designed and manufactured by a milling vertical machine.
2. Experimental results indicate that the change in microrelief for ferromagnetic and non-magnetic can improve the surface roughness. Surface roughness for non-ferromagnetic can be reduced by 30 – 40%, and for ferromagnetic material can be reduced by 40 - 60% with properly selected technological parameters.
3. Within the examined range, the increase in the volume of powder (the largest impact) improves the finishing quality of surface for non-ferromagnetic material because the machining pressure between the magnetic brush and workpiece increases considerably with the increase in the volume of powder. The higher

value of the volume of powder for ferromagnetic material may even deteriorate the quality of surface finish, but the finishing quality improves with the decrease in the coil current (the largest impact) because an additional magnetic pole in the gap, which helps in the creation of brush.

4. The surface quality for non-ferromagnetic is highly sensitive to the volume of powder and the working gap which are quite significant parameters as compared to current and feed rate. On the other hand, for the ferromagnetic material, the current and the working gap are quite significant parameters as compared to volume of powder and feed rate.

References

[1] Dhirendra K. Singh . V. K. Jain . V. Raghuram,(2006) - Experimental investigations into forces acting during a magnetic abrasive

finishing process. Int J Adv Manuf Technol 30: 652–662.

[2] O. V. Stepanova, I. V. Uvarova, V. P. Smirnov, I. I. Timofeeva, and A. A. Rogozinskaya. 2005, Effect of magnetic abrasive finishing on the chemical and phase composition of TiC coatings on VK8 alloy. *Powder Metallurgy and Metal Ceramics*, Vol. 44, pp.451-454, Nos. 9-10,

[3] Geeng-Wei Chang, Biing-Hwa Yan, Rong-Tzong Hsu, (2002) – Study on cylindrical magnetic abrasive finishing using unbounded magnetic abrasive. *International Journal of Machine Tools & Manufacture* 42 575–583.

[4] Sung-Lim Ko, Yuri M .Baron, Jeong Won Chae(2006) - Development of Deburring Technology for Micro Drilling Burrs using. Konkuk University, Seoul, Korea** Saint-Petersburg State Polytech University, Saint-Petersburg, Russia. E-mail : slko@konkuk.ac.kr

[5] Yu. M. Baron. 1.Yu. Baron,1975. Technology of abrasive finishing in the magnetic field. - Leningrad, 1975, 128p. (Rus)

[6] Yu. M. Baron 1986, Magnetic abrasive and magnetic finishing of products and cutting tools.- Leningrad,, 172 p. (Rus)

[7] Ching-Tien Lin . Lieh-Dai Yang . Han-Ming Chow 2006.,– Study of magnetic abrasive finishing in free-form surface operations using taguchi method. Springer-Verlag London Limited

[8] S.L. Ko, Yu M. Baron, J.I. Park,(2007) - Micro deburring for precision parts using magnetic abrasive finishing method. *Journal of Materials Processing Technology* 187–188 19–25

[9] Dharendra K. Singh V.K.Jain V. Raghuram,26-31, 2003. – Superfinishing of alloy steels using magnetic abrasive finishing process. *Mechanical Engineering Department, Indian*

Institute of Technology Kanpur, Kanpur - 208016 (India). American Society for precision Engineering (ASPE), Portland, oregon, USA, october

[10] K.A.Gogaev, V.V.Nepomnyashchii T. V. Mosina; I. P. Neshpor; M. Leonowicz, 2006.- Special Features of the Magnetic Abrasive Machining, *Novye ognepory*, No 1. Pp.53-55, January,

[11] Yuri M. Baron' Sung Lim Ko, Elena Repnikova, 2001 – Experimental Verification of Deburring by Magnetic Abrasive Finishing Method. St.-Petersburg State Polytechnical University, Dr.Sc, Prof, Polytechnichskaya Str., 29, St.Petersburg, 194251, Russia,.

[12] P.I. Yascheritsin , L.E. Sergeev, M.I. Sidorenko(1997). - The Comparative Appraisal of Quality Characteristics of Holes after Different Finishing Methods. *Advanced Performance Materials* 4, 337–347

[13] T.Shinmura, k. Takajava, E. Hatano,(1985), Study on magnetic abrasive process-application to plane finishing. *Bull, Jpn. Soc. Prec. Eng.* 19(4) 289-291.

[14] R.K. Roy, A Primer on the Taguchi Method, *Competitive Manufacturing Series*, Van Nostrand Reinhold, New York, 1990.

[15] D.K. Singh, V.K. Jain, V. Raghuram,(2004), Experimental investigations into magnetic abrasive finishing of alloy steel, *Proceedings of JSME sponsored International Conference on Leading Edge Manufacturing in 21st Century (LEM-21)*, Nov 3–6, Niigata, Japan, pp. 403–408

[16] D.G. Montgomery, *Design and Analysis of Experiments*, 5th ed. Wiley, New York, 2000.

تأثير طريقة النحت بالحث المغناطيسي على سطح معادن فلزية ولافلزية

نزار قيس محمد نايف

يحيى محي حمد

علي حسين كاظم

جامعة بغداد- كلية الهندسة الخوارزمي-

قسم هندسة عمليات التصنيع

الخلاصة:

يعتبر التنعيم بالنحت المغناطيسي من طرق التنعيم المتقدمة، والتي تحسن من جودة السطوح وتحسن أداء المنتجات. يكون التنعيم التكنولوجي للسطوح المستوية بهذه الطريقة اقتصادياً جداً في الحقول الصناعية.

تم تصميم وتصنيع ملف محاثة كهرومغناطيسي يستخدم لتنعيم السطوح المستوية وتم تركيبه على ماكينة تفريز عمودية، كما تم إنتاج مسحوق فيرو ناحت ضمن ظروف تحكم خاصة.

هنالك عدة متغيرات مثل التيار في الملف وفجوة التشغيل وحجم المسحوق الناحت وسرعة التغذية تؤثر تأثيراً كبيراً على جودة السطوح. توضح ورقة البحث هذه تطبيق طريقة تاكوشي في تصميم التجارب لإيجاد تأثير هذه المتغيرات المهمة على جودة السطوح المتكونة من التنعيم بهذه الطريقة. في الجزء العملي، تم دراسة نوعين من المواد (سبيكة الألمنيوم 7020 والصلب المقاوم للصدأ 410) ولمختلف المتغيرات. تم الحصول على نموذج رياضي إحصائي باستخدام برنامج الحاسوب SPSS، يوضح العلاقة بين المتغيرات وجودة السطح.