



A Dual Band Non-Concentric Circular Rings Microstrip Antenna Design for Wi-Fi Application

Kareem Madhloom Gatea

Author affiliations:

Department of Electronics and Communication Engineering,
Al-Nahrain University, Iraq

Email:

kareem.madhloom.1@nahrainu.niv.edu.iq

Paper History:

Received: 31st Aug, 2024

Revised: 22nd Sep, 2024

Accepted: 27th Sep, 2024

Abstract

In this paper we design a dual band patch antenna for Wi-Fi application and using it works in two different frequencies the first one in bandwidth of 480 MHz and impedance bandwidth of 18.75% (2.32. to 2.8 GHz) with resonant frequency 2.56 GHz this band can cover the Wi-Fi the second bandwidth is 4 GHz and the impedance bandwidth 53.33% (5 GHz – 9 GHz). With resonant frequency 7.5 GHz, this band of frequency can cover the WLAN 5.8GHz, the 6GHz band its operate at frequency range (5.925 - 7.125 GHz) it used for unlicensed Wi-Fi with bandwidth of 1.2 GHz its application on Wi-Fi 7 and Wi-Fi 6E. Another application of the antenna in 8 GHz band its operate at the range (7.725 – 8.275 GHz). We use the CST package to design and simulated the propose antenna with dimensions of 35 mm×21 mm×1.6 mm.

Keywords: Circular Patch Microstrip Antennas, Rings Antenna, Wi-Fi, Dual-Band, WLAN, , 8GHz Band.

تصميم هوائي ثنائي النطاق ذو حلقات دائرية غير متحدة المركز لتطبيقات Wi-Fi
كريم مظلوم كاطع

الخلاصة:

في هذه الورقة البحثية قمنا بتصميم هوائي رقعة ثنائي النطاق لتطبيق Wi-Fi وباستخدام حلقتين دائريتين غير متحدة المركز يعمل بتدردين مختلفين الأول بعرض نطاق 480 ميغا هرتز وعرض نطاق معاوقة 18.75% (2.32 إلى 2.8 GHz) مع تردد رنين 2.56 جيجا هرتز يمكن لهذا النطاق تغطية Wi-Fi وعرض النطاق الثاني هو 4 جيجا هرتز وعرض نطاق المعاوقة 53.33% (5 جيجا هرتز - 9 جيجا هرتز). مع تردد رنين 7.5 جيجا هرتز ، يمكن لهذا النطاق من التردد تغطية شبكة WLAN 5.8 جيجا هرتز ، ويعمل نطاق 6 جيجا هرتز في نطاق التردد (5.925 - 7.125 GHz) ويستخدم لتطبيق Wi-Fi غير المرخصة بعرض نطاق 1.2 جيجا هرتز وتطبيقه على Wi-Fi 7 و Wi-Fi 6E. وتطبيق آخر للهوائي في نطاق 8 جيجا هرتز يعمل في النطاق (7.725 - 8.275 GHz). نستخدم حزمة CST لتصميم ومحاكاة الهوائي المقترح بأبعاد 35 × 21 × 1.6 مم.

1. Introduction

The wireless communication is one of promising research topic in the recent years. Antenna represent the backbone for any wireless communications system. Many papers has been written in this field but microstrip antenna always on demand because it has low cost, profile, and light weight, antenna has single resonant frequency. multiple frequency bands are needed for modern wireless communications system. A dual-band rectangular patch was design for wireless communication with defected ground plane to meet the requirement of 2.5GHz and 3.5GHz [1]. A X-shaped patch designed to get dual and triple band frequencies using five rectangular slots to produce Ku and K bands its can be used for satellite communication [2]. For Wi-Fi frequency a wide

bandwidth and high gain antenna proposed and simulated using CST studio suite [3]. L-shaped antenna which coupled with ground parasitic resonator to produce a tri-bands for WLAN, WiMAX and Bluetooth application was proposed [4].

A four-element dual-band MIMO antenna for LTE and 5G application to cover the frequency band (1550-2650 MHz) and (3350-3650 MHz) was introduce [5]. A dual band is achieved by adding a different slot shape to radiating patch with inverted V-shape and inverted C-shape to get (2.98-5.3GHz) and (6.6-7.2GHz) [6]. A tri band antenna that operates at 2.45, 3.5 and 5.8 GHz are designed using coplanar waveguide, the patch is loaded with inverted L-shaped stub to gate 2.4 GHz and other open-end stubs was added to get the 3.5 and 5.8GHz [7].



The propose antenna is very easy to fabricated and has small size, also the antenna has large bandwidth impedance 480 MHz at the first band and 4 GHz in the second band that can increase the data traffic, so large data can be transfer per unit time

2. The Proposed Antenna Design

A single-band circular patch antenna was designed using the following equations 1 and 2 [8]

$$a = \frac{F}{\left\{1 + \frac{2h}{\pi\epsilon_r F} \left[\ln\left(\frac{\pi F}{2h}\right) + 1.7726 \right] \right\}^{1/2}} \quad \dots(1)$$

$$\text{Where } F = \frac{8.791 \times 10^9}{f_r \sqrt{\epsilon_r}} \quad \dots(2)$$

Where a is the radius of the patch, h the thickness of substrate, ϵ_r is relative permittivity of the substrate and f_r is the resonant frequency.

When we used the above equations to design circular patch at 2.4 GHz and choose FR-4 as a substrate with $\epsilon_r = 4.3$ and $h=1.6$ mm we get $a = 17.14$ mm and we choose the width and length of substrate 46mm the antenna named AntI is shown in Fig. 1 and its return loss is shown in Fig.2. Its feeding probe fed from underneath by coaxial line under the center of the circle by 7mm toward the - y axis. and we used fall ground plane.

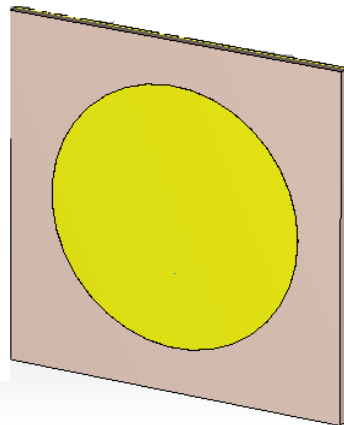

Figure (1): Ant I the radius of antenna 17.14mm

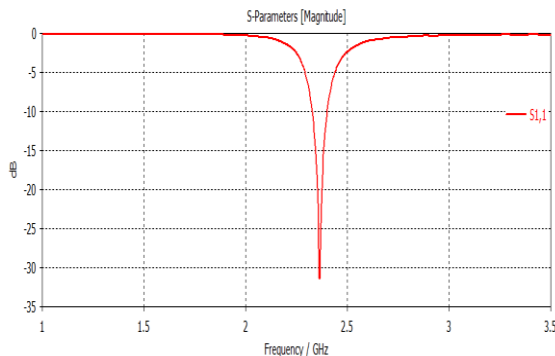

Figure (2): The return loss of Ant I

Then the geometry of the Ant I was modifying to ring microstrip antenna named as Ant II with the same substrate type and thickness of Ant I but with defected ground plane this modification led us to get the triple

band with resonant frequency at 2 GHz, 5.9 GHz and 8.2GHz. fig. 3 show the Ant II front and back view and the S11 show in Figure 4m while Table 1 show the dimensions of Ant II

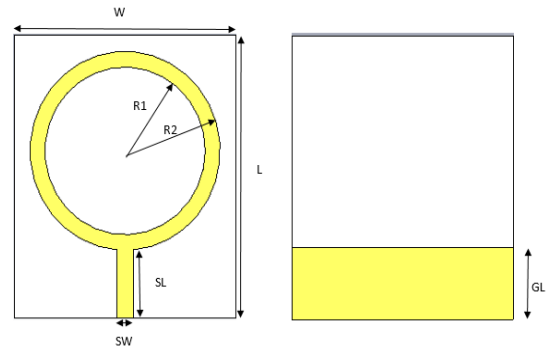

Figure (3): Front and back view of AntII

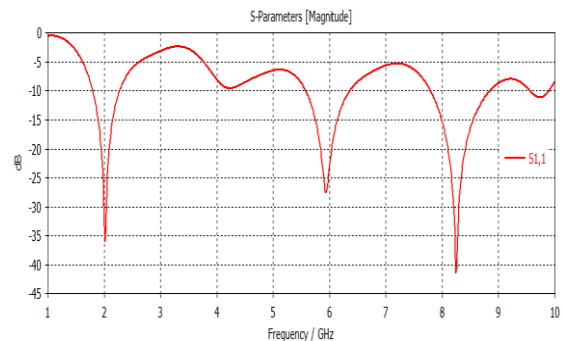

Figure (4): the return loss of AntII

Table (1): The optimize dimensions of Antenna AntII (in mm)

W	L	R1	R2	SL	SW	GL
40	49	15	17.2	11.86	2.9	12

The propose antenna printed on FR-4 substrate its thickness $h=1.6$ mm and $\epsilon_r = 4.3$. This material has excellent mechanical and electrical properties and it used widely for manufacturing printed circuits boards also it has stability in use and ease to fabrication. A microstrip line used to feed the patch with power to radiated it. The antenna has a compact structure with to $WP \times LP \times h$. the radiating patch is two non-Concentric circular rings the propose antenna is shown in fig. 5 and the optimal parameter are listed in table 2.

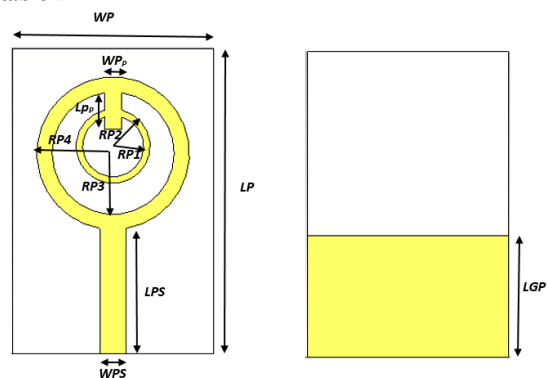

Figure (5): Front and back view of Ant III



Table (2): The optimize dimensions of Antenna Ant III

Parameter	Value(mm)	Parameter	Value(mm)
WP	21	WP _p	2
LP	35	LP _p	4.22
RP1	3.5	LPS	14.62
RP2	4.25	WPS	2.9
RP3	7	LGP	14
RP4	8.75		

3.Parametric Study of Propose Antenna:

To see the effect, of each parameter a parametric study is important on some parameter of the antenna we choose two parameters RP4 it represents the radius of the external ring and RP2 it represents the radius of the internal ring to get an optimized antenna performance. Fig. 6 show the return loss different value of RP4 and constant of RP2 and fig.7 show the return loss of different value of RP2 and constant value of RP4.

It can be seen that the best S11 parameter optimum for our paper when RP4=8.75 mm and RP2=4.25 mm also we note that when the value of the radius of the external ring change its affect the starting of the second band and does not affect the ending of the second band but when the value of the radius of internal ring has change the its effect on the ending of the second band but does not affect the starting of the band. Also, the changing in the RP4 effect the resonant frequency of the first band but the changing in RP2 does not affect the resonant frequency of the first band.

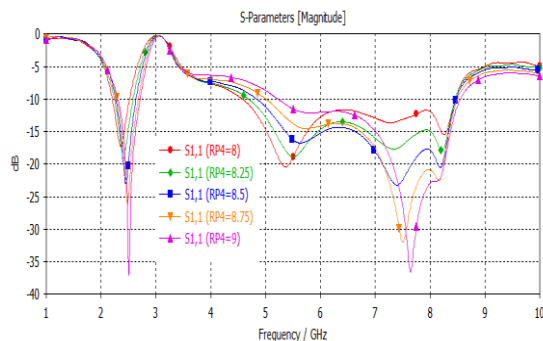

Figure (6): the return loss different value of RP4 and constant of RP2

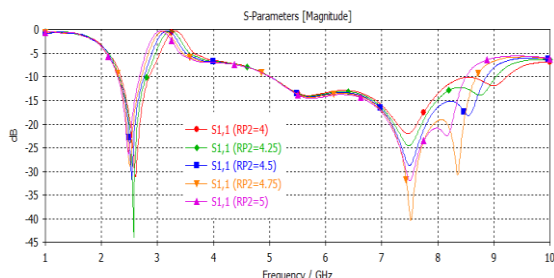

Figure (7): the return loss of different value of RP2 and constant value of RP4.

4.Results and Discussion:

The proposed antenna (AntIII) is optimized and investigated by CST microwave studio the return loss (S11) is shown in fig.8 and the realized gain of the Ant III is shown in fig. 9. From the fig. 8 we note that the

operating frequency of the first band is 480 MHz (2.32 to 2.8 GHz) its suitable for Wi-Fi application with maximum return loss -45.6 dB and at the second band the operating frequency is 4GHz (5 to 9 GHz) with maximum return loss is -24.4 dB many applications are designed to work in this band of frequency the like WLAN because it's clustered around 5.8GHz also the propose antenna cover the 6GHz band that FCC open it for unlicensed Wi-Fi use also the Wi-Fi 7 and Wi-Fi 6E are operating in the 6GHz band. The second band can cover the 8 GHz band which is use by high capacity and medium capacity and fixed point-to-point links.

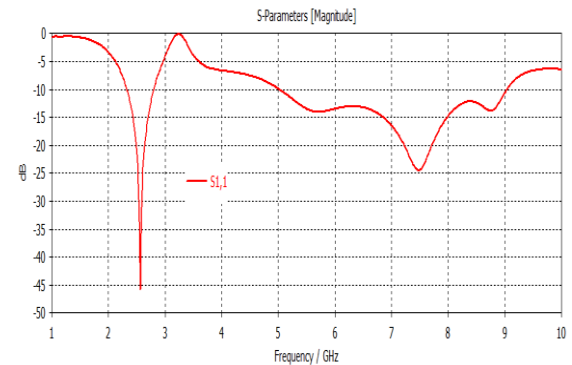

Figure (8): The return loss of AntIII

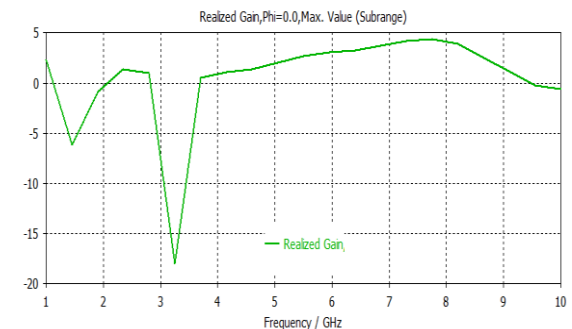
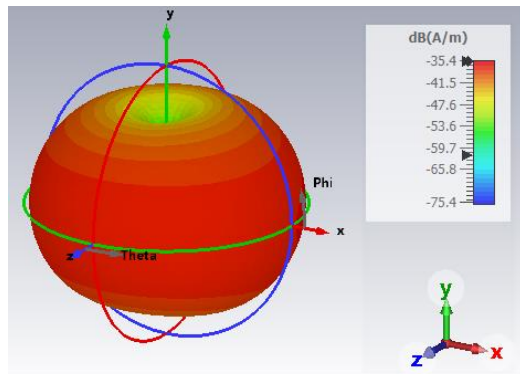

Figure (9): The realized gain of the Ant III

As shown in figure 9 the realized gain in first band is about 1.4 dB and for the second gain is 4.35 dB this gain makes the AntIII suitable to provide a good communication link for Wi-Fi application. Fig. 10a and b show the far field radiation pattern of the AntIII antenna for both band at resonant frequency, the figure shows the radiation pattern of AntIII is omnidirectional for the first band at 2.56 GHz and approximately omnidirectional for the second band at 7.5 GHz.

To observe the effect of the resonant frequencies the surface current of AntIII at 2.56 GHz and at 7.5GHz are shown in fig. 11 and fig. 12. We note that the surface current in the 2.56 GHz is concentrate mainly in the strip line feeding and partially in the outer ring, but at the second resonant frequency 7.5 GHz the surface current is concentrate on the strip line feeding and mainly concentrate at the inner ring that indicate the two rings are used to generate the two resonant frequencies.

Table 3 show the result of comparison of the propose double rings antenna with related prior antenna the propose antenna has a good performance with respect to other antenna and its suitable for wireless application.



(a)

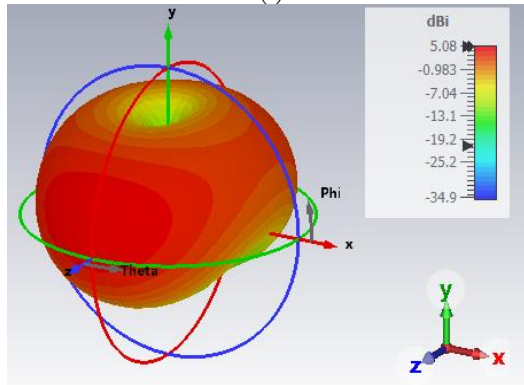

(b)

Figure (10): the far field radiation pattern (a) at 2.56 GHz (b) at 7.5 GHz

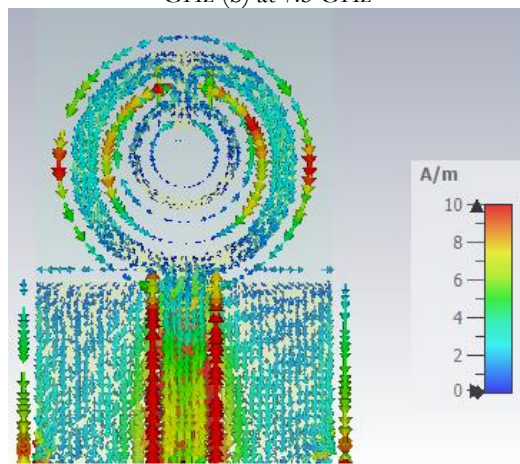

Figure (11): The surface current at 2.56 GH

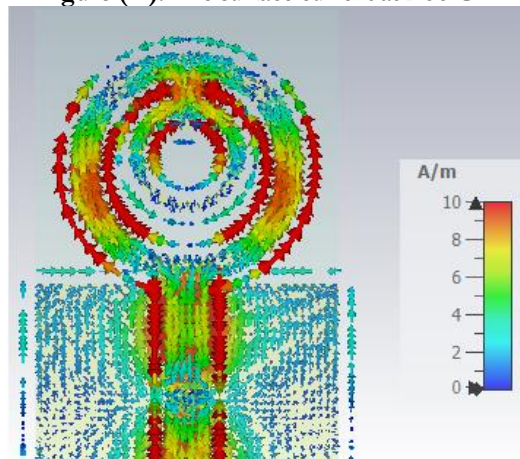

Figure (12): The surface current at 7.5 GHz

Table (3): The comparison of propose antenna with related work

Ref.	Dimensions (mm)	Operating Frequency (GHz)	S11 (min. value in dB)	Band-width (MHz)
[3]	10×50	2.4 5.8	-31.17 -42.05	600 1250
[9]	24×21	2.5 5.8	-29.9 -15.16	100 200
[10]	50×50	2.4 5	-17.6 -12.8	210 1010
[11]	39.4×32.9	2.4 5.8	Less -15 Less -30	72 715
Propose antenna	35×21	2.5 5	-45.6 -24.4	480 4000

5. Conclusions:

In this paper, two non-Concentric circular rings microstrip patch antenna is designed to operates in two frequency bands with enhanced bandwidth, at the first band the bandwidth is 480 MHz at resonant frequency 2.56 GHz and return loss -45.6 dB and 4 GHz in the second band at resonant frequency 7.5 GHz and return loss -24.4 dB, the characteristics of the propose antenna meet the requirement of the Wi-Fi application at the frequencies 2.4 GHz, 5.8 GHz, 6GHz band for unlicensed Wi-Fi and the 8 GHz band. The realized gain in first band is about 1.4 dB and for the second gain is 4.35 dB.

6. References:

- [1] Imad Ali and Ronald Y. Chang “Design of Dual-Band Microstrip Patch Antenna with Defected Ground Plane for Modern Wireless Applications “ 978-1-4799-8091-8/15/ 2015 IEEE
- [2] M. Samsuzzaman , M. T. Islam, N . Misran, M.A. Mohd Ali “Dual band X shape Microstrip Patch Antenna for Satellite Applications” The 4th International Conference on Electrical Engineering and Informatics (ICEEI 2013)
- [3] Yasar Kaplan1, Cem Gocen “A Dual-Band Antenna Design for 2.4 and 5 GHz Wi-Fi Applications” European Journal of Science and Technology Special Issue 34, pp. 685-688, March 2022.
- [4] Peshal B. Nayak, Sudhanshu Verma and Preetam Kumar “A Novel Compact Tri-Band Antenna Design for WiMAX, WLAN and Bluetooth Applications” arXiv:2106.12884v1 [cs.NI] 13 May 2021.
- [5] Wazie M. Abdulkawi, Waqar Ahmad Malik, Sajjad Ur Rehman, Abdul Aziz, Abdel Fattah A. Sheta and Majeed A. Alkanhal “Design of a Compact Dual-Band MIMO Antenna System with High-Diversity Gain Performance in Both Frequency Bands” Micromachines 2021, 12, 383
- [6] Hussain, M.B.; Butt, M.; Nadeem, Z.; Zahid, M.; Amin, Y. “Design of Dual-Band Microstrip Patch Antenna for Wireless Local Area Network Applications”. *Eng. Proc.* 2023, 46, 3.
- [7] Azimov Uktam Fakhridinovich, Md. Abu Sufian, Wahaj Abbas Awan1, Niamat Hussain And Nam Kim “ A Compact Antenna With Multiple Stubs for ISM, 5G Sub-6-GHz, and



- WLAN” IEEE accesses ,vol. 11 2023, 130418-130425
- [8] Balanis, C. A. (2005). Antenna theory analysis and design, A JOHN WILEY & SONS.
- [9] Rabnawaz Sarmad Uqaili, Junaid Ahmed Uqaili1, Sidrish Zahra2, Faraz Bashir Soomro, Ali Akbar “A Study on Dual-band Microstrip Rectangular Patch Antenna for Wi-Fi” proceedings of Engineering and Technology Innovation, vol. 16, 2020, pp. 01 – 12
- [10] Vijay Kumar Srivastava, Garima Saini “A Dual Wide-Band Slotted Rectangular Patch Antenna for 2.4/5 GHz WLAN Applications”, International Journal of Engineering Research & Technology (IJERT), Vol. 5, Issue 07, July 2016.
- [11] F. Meng and S. Sharma, “A single feed dual-band (2.4 GHz/5 GHz) miniaturized patch antenna for wireless local area network (WLAN) communications,” Journal of Electromagnetic Waves and Applications, vol. 30, no. 18, pp. 2390-2401, November 2016.