

## A Case Study of Random Vibration Response Modeling of Two-Story-Building Due to Earthquake

**Mohsin Juber Jweeg**  
 PO Eng. Dep.  
 Al-Nahrain University  
[mohsinjj@yahoo.com](mailto:mohsinjj@yahoo.com)

**Mahmud R. Ismail**  
 PO Eng. Dep.  
 Al-Nahrain University  
[mahmech2001@yahoo.com](mailto:mahmech2001@yahoo.com)

**Salah Aldein M. R.**  
 Civil Eng. Dep.  
 Salah Alden University  
[salah\\_ismail@yahoo.com](mailto:salah_ismail@yahoo.com)

### Abstract:

In this work a general dynamic response of two-story building due to earthquake is investigated. A spatial case of two degree mass-spring-damper random vibration model is employed. The base excitation acceleration is represented according to the well-known regression model by Kanai-Tajimi in term of the power spectrum density (PSD). The transfer function between the ground and the roofs are evaluated assuming transverse modes of vibration.

A case study of typical two symmetrical story building manufactured from reinforced concrete and steel is investigated. The vibration parameters such as effective mass and stiffness and damping are calculated according to the ACI 318-11 code. The natural frequencies, mode shape and transfer functions are calculated and plotted. The PSD acceleration at the roofs are evaluated from which the mean and standard deviation of the random acceleration are found. The drift at the walls is calculated and compared with the allowable limits recommended by IBC 2015. It is found that the probability of the building to be safe is between (13.74 - 7.35)% for the first story and (8.7 - 1.67) % for the second.

### 1. Introduction

Earthquakes are natural geologic phenomena caused by sudden and rapid movement of large volume of the rock. The violent shaking associated with earthquake are results of rupture and slippage along fractures in earth crust called faults. The earthquake occur at a depth from 5 to 700 kilometer at a point called focus as shown in fig.(1). During a large earthquake a massive amount of energy will be released and cause heat and seismic waves[1].

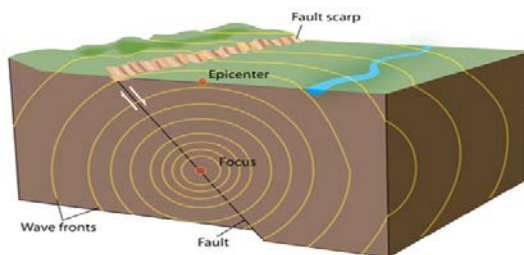


Figure 1: Earthquake geologic model [1]

Earthquakes are produced by the rapid release of elastic energy stored in tectonic plates that has been deformed by differential energy stress [2].

There are two groups of waves produced by slippage of the plates mass. One of them called surface waves which travels along the outer part of the earth and second called body waves travels along the inner part of the earth. Body waves are divided in two types called primary waves or P and secondary waves or (S) as shown in Fig.(2)[3].

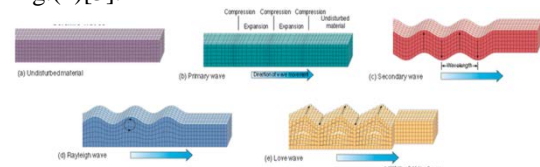


Figure 2: Seismic waves[3]

The real characteristics of seismic or earthquake is a random vibration phenomenon. As an opposite of classical vibration, random vibration is in-deterministic in which the instantaneous amplitudes are not predictable since the amplitude at any point in time is not related to that at any other point in time [4]. Many researchers investigated and analyzed the seismic of building and steel frames. The base acceleration maybe approximated as a transient shock pulse [5]. However, for more realized modeling the base acceleration the regression technique is utilized. In this case the seismic excitation of many recorded are collected and managed by using statistical tools. Many regression models for estimating power spectral density function of ground acceleration are proposed such as those of [6] and [7]. The subject of evaluating the dynamical behavior of multistory building and tower are very familiar to help for safe and reliable design and to improve and update the coding at the the zones under earthquake effect around the world. The earthquake map is subjected to change due to many geological factors and climate change. In Iraq some area undergo at this effect hence it is important to take these change into the account [8]. In this work the random vibrations analysis of earthquake is performed by using a suitable PSD Model to determine the probability of the occurrence of specified rang of safety and dangerous parameters of a system. A case study

of sample building is used for numerical solution The building is typically selected ,and the properties of ground clay are chosen to suit for Baghdad conditions

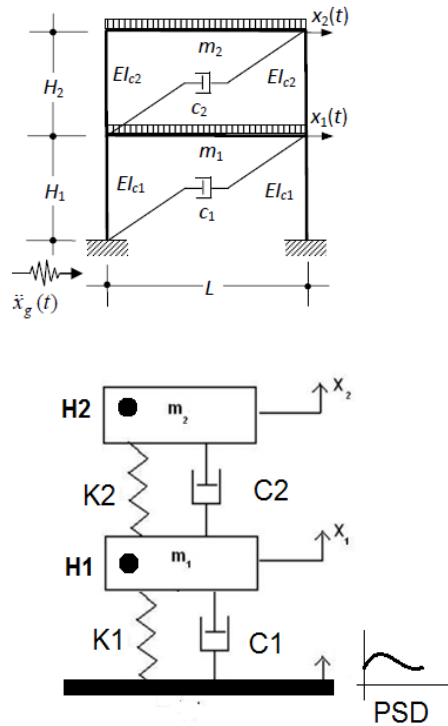


Figure.3: Mathematical model

The equation of forced vibration of multi degree of freedom mass-spring-damping model can be written as [11] ;

$$[M]\{\ddot{x}\} + [C]\{\dot{x}\} + [K]\{x\} = \{\ddot{a}_g\} \quad (1)$$

Where the mass ,damping and stiffness matrices . In case of two degree of freedom these matrices take the following forms ;

$$[M] = \begin{bmatrix} m_1 & 0 \\ 0 & m_2 \end{bmatrix}, [C] = \begin{bmatrix} c_1 + c_2 & -c_2 \\ -c_2 & c_2 \end{bmatrix} ,$$

And

$$[K] = \begin{bmatrix} k_1 + k_2 & -k_2 \\ -k_2 & k_2 \end{bmatrix} \quad (2)$$

Substituting eqs (2) into (1) one can get;

$$\begin{bmatrix} m_1 & 0 \\ 0 & m_2 \end{bmatrix} \begin{Bmatrix} \ddot{x}_1 \\ \ddot{x}_2 \end{Bmatrix} + \begin{bmatrix} c_1 + c_2 & -c_2 \\ -c_2 & c_2 \end{bmatrix} \begin{Bmatrix} \dot{x}_1 \\ \dot{x}_2 \end{Bmatrix} + \begin{bmatrix} k_1 + k_2 & -k_2 \\ -k_2 & k_2 \end{bmatrix} \begin{Bmatrix} x_1 \\ x_2 \end{Bmatrix} = \begin{Bmatrix} -m_1 \\ 0 \end{Bmatrix} \ddot{x}_g(t) \quad (3)$$

From solving of eq.(3) ,the transfer function  $H_1(\omega)$  between the ground and first floor is can be obtained as follows;

$$H_1(\omega) = \frac{k_1 + i\omega c_1}{(k_1 - \omega^2 m_1) + i\omega c_1} \quad (4)$$

While, the transfer function  $H_2(\omega)$  between the first and the second floor is;

$$H_2(\omega) = \frac{(k_1 + i\omega c_1)(k_2 + i\omega c_2)}{\{[-\omega^2 m_1 + i\omega(c_1 + c_2) + (k_1 + k_2)](k_2 - \omega^2 m_2 + i\omega c_2) - (k_2 + i\omega c_2)^2\}} \quad (5)$$

## 2.1: Formulation of random earthquake excitation

In 1935 Charles Richter development the first magnitude scale using seismic records [9]. The waves weaken as the distance between the focus and the seismograph increases, Richter developed a method for collecting data from several measuring stations as shown in the fig.(4) .

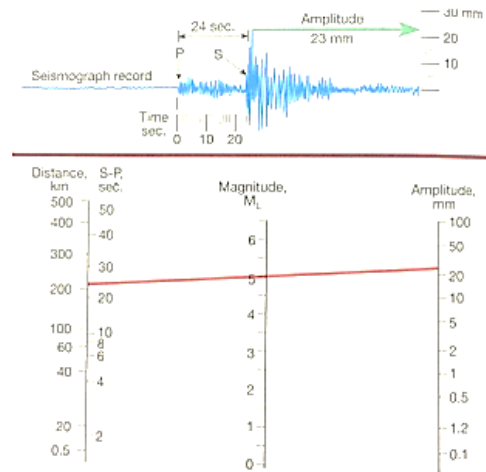


Figure 4: Magnitude scale of seismic records[9]

A large number of ground acceleration data are measured from several stations and at many time intervals .Such data are random .By using the statistical tools and assuming stationary ergodic random function the normal distribution can be found .The best manipulation for such large random samples data is by taking the power spectrum density (PSD) .The time history of the random data firstly subjected the autocorrelation function as follows [10];

$$R_f(\tau) = \lim_{T \rightarrow \infty} \int_{-T/2}^{T/2} f(t)f(t + \tau)dt \quad (6)$$

Finally, the PSD function can be evaluated from the Fourier transformation of  $R_f(\tau)$  which is;

$$S_f(\omega) = \int_{-\infty}^{\infty} R_f(\tau)e^{-i\omega\tau}d\tau \quad (7)$$

Many PSD models are available in the literature for represening the earthquake ground acceleration ,however the most reliable model is the Flitered Kanai –Tajimi Spetrum which is as follows [6] ;

$$S_{KT} = S_o \frac{1 + 4\zeta_g^2(\omega/\omega_g)^2}{[1 - (\omega/\omega_g)^2]^2 + 4\zeta_g^4(\omega/\omega_g)^2} \quad (8)$$

Where  $S_o$  is the white noise spectrum density , $\omega_g$  and  $\zeta_g$  are the charestersitics frequency and damping ratio of the ground.

If  $S_f(\omega)$  and  $S_o(\omega)$  be the power spectral density PSD of the input and the output accelerations ,respectively , then one can write:[10]

$$S_o(\omega) = H^*(\omega)H(\omega)S_I(\omega) \tag{9}$$

$H(\omega)$  is the transfer function of the vibrated system and (\*) stands for complex conjugate. When the output PSD is calculated, It is possible to construct Gaussian random signal with zero mean. and as the follow [10] ;

$$\overline{x^2} = \int_0^\infty S_o(\omega)d\omega \tag{10}$$

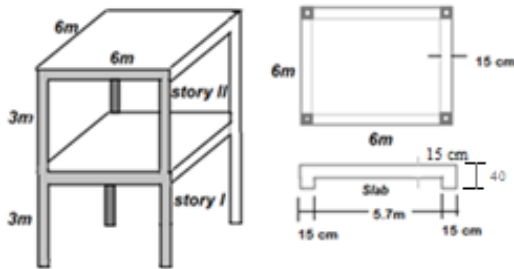
This implies that the mean square value of the random acceleration can be found by calculating the area under the PSD curve .

Since the mean of the acceleration is chosen zero , The slandered deviation  $\sigma$  is ;

$$\sigma = \sqrt{\overline{x^2}} \tag{11}$$

**Case Study**

Two symmetrical story with the detailed dimensions are shown in fig.(5) is considered for this study .The materials are concrete and steel. The ACI 2015 code procedure is used to estimate the effective masses of the roofs .The stiffness of the building is assumed as a result of the elastic deflection of the columns which are vertical cantilevers beams.



**Figure 5:** Sample case study building

The following equations and slandered data are used;

Mass of the slab (dead weight ) =  $\rho V_{slab}=11700$  kg

Finishing load = 3730 kg

Live load= 6500 kg (assuming 200 kg /m<sup>2</sup>)

Un factored mass = 28900 kg

Effective modulus of elasticity =4700 (Fc)<sup>1/2</sup>

Where; Fc=cylinder concrete compressive strength = 25 Mpa

Effective moment of inertia = 0.7 x Ig

Where; Ig= 300<sup>4</sup>/ 12 m<sup>4</sup>

Stiffness per column =12 E I /L<sup>3</sup>

Number of columns per story=4

Damping per story =540 Ns/m [11]

**Table (1)** The main required data for the two-story- building

Story no.	Effective mass kg	Stiffness N/m	Damping N. s/m
I	28.9x10 <sup>3</sup>	4.935x10 <sup>8</sup>	540
II	28.9x10 <sup>3</sup>	4.935x10 <sup>8</sup>	540

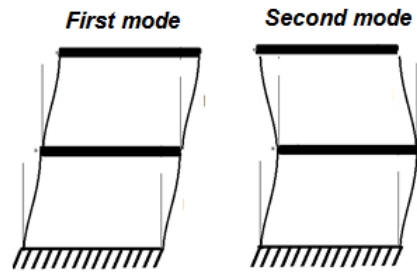
**3- Results and discussions**

The free vibration properties of the case study building which are the natural frequencies and normal modes are calculated and plotted by using MATLAB R2015a .In table (2) the first and second natural frequencies are presented

**Table 2:** Natural frequencies for the two-story- building

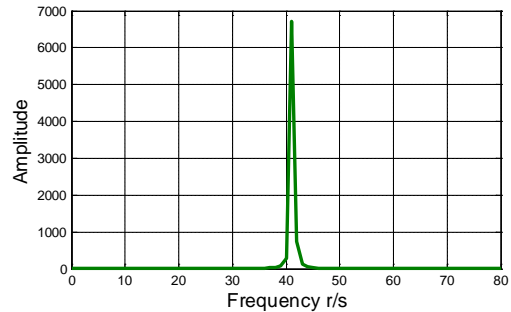
First mode natural frequency	23.45 rad/s	3.7322 Hz
Second mode natural frequency	67.22 rad/s	10.698 Hz

In fig.(6) the normal modes of vibrations are plotted ;

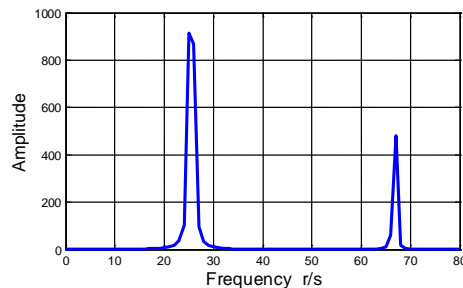


**Figure 6:** Normal modes of free vibrations

The transfer function for the first story is plotted in fig.(7) and that for the second story is plotted in fig.(8) >as it is clear from these figures the pack response occurs at the natural frequencies.



**Figure 7:** Transfer function of first story



**Figure 8:** Transfer function of Second story

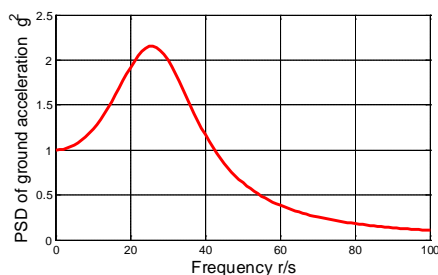
The Flitered Kanai –Tajimi power specturm density (PSD) model due to the random acceleration caused by seismic waves is plotted in

fig.(9) in plotting the figure the following parameters of ground are assigned ;

$S_o = 1 \text{ g}^2$  (power specturm density for white nose )  
 $\omega_g = 19 \text{ r/s}$  (calculated from stiffnes and mass data given in [13])

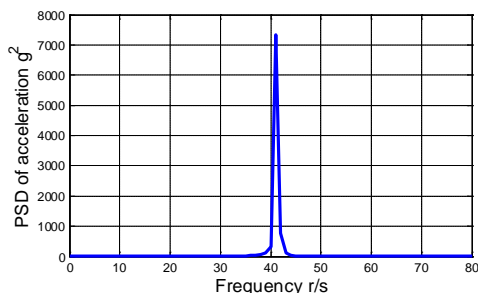
$\zeta_g = 0.4$  (calculated from the logarithmic decrement of the response curve shown in fig.(9) of ref[13])  
 The natural frequency and damping ratio  $\omega_g$  and  $\zeta_g$  are the main dynamic properties of clay founded in Baghdad [13]

The frequency range are from 0 to 100 r/s is choosen to include the range frequencies used in plotting the transfer functions are shown in figs.7 and 8



**Figure 9:** PSD of ground acceleration

The outputs PSD due to the base acceleration for each story are calculated due to eq.(9) by using MATLAB R2012 software and the results are plotted in figs (10 and 11). In the same program the square mean and standard deviation are also calculated and presented in table (3). These data are found by using the numerical integration method according to equations 10 and 11. From these statistical data the Gaussian normal distribution curves are plotted by using the statistical tools supplied in MATLAB .



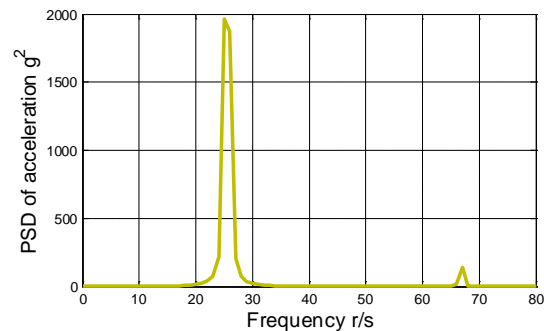
**Figure 10:** PSD of acceleration at first floor

**Table (3)** statistical acceleration output data

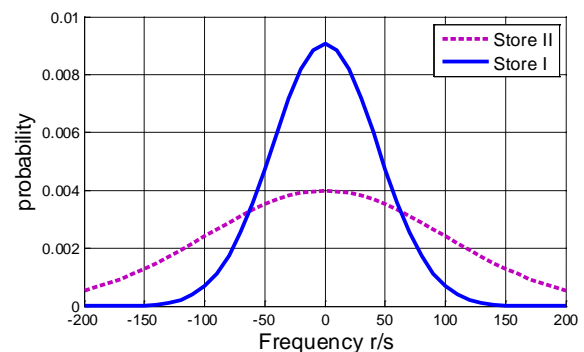
Roof no.	Acceleration Square mean ( $\text{g}^2$ )	Acceleration Standard deviation (g)
I	$4.8386 \times 10^3$	69.56
II	$9.079 \times 10^3$	95.2836

To explore the practical application and the benefit of the data given in table (3). The drift of the walls due to the effect of the acceleration according to the earthquake is calculated and

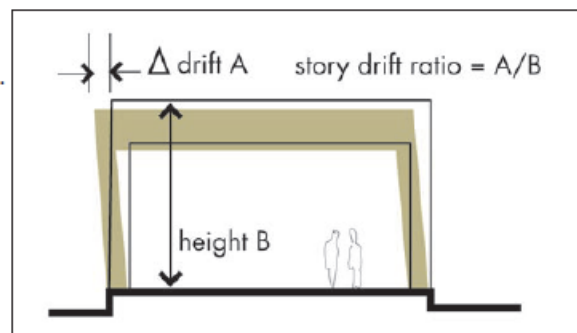
compared with the allowable drift recommended by the IBC code .It is to be mention that the Drift limits serve to prevent possible damage to interior or exterior walls that are attached to the structure and which might be cracked or distorted if the structure deflects too much laterally, creating cracking forces in the member. Thus IBC requires that drift be limited in typical buildings to between 0.02 and 0.01 times the building height, depending on the occupancy and type of the building. fig.(13).[14]



**Figure 11:** PSD of acceleration at second floor



**Figure 12 :** Normal distribution of acceleration for Building



**Figure 13:** Wall drift in building [14]

From table the drift for every story is calculated as follows ;

Inertia force at the column tip ,  $F_c = m a$   
 Drift due to earthquake per column  $\Delta e = F_c L^3 / 3EI$   
 Minimum IBC allowable drift  $\Delta_{min} = 0.01 h$   
 Maximum IBC allowable drift  $\Delta_{max} = 0.02 h$  (12)

Where  $a$  ,  $h$  are the acceleration and column height ,respectively .

To evaluate the probability that  $\Delta e$  being safe within the minimum and maximum allowable drift the following statistical equation is used ;

$$Prob[\epsilon_1\sigma \leq \Delta \leq \epsilon_2\sigma] = \frac{1}{\sigma\sqrt{2\pi}} \int_{\epsilon_1\sigma}^{\epsilon_2\sigma} Exp\left(\frac{-(\Delta-\mu)^2}{2\sigma^2}\right) d\Delta \quad (13)$$

And the probability of exceeding this limits from the following equation ;

$$Prob[\Delta > \epsilon\sigma] = \frac{1}{\sigma\sqrt{2\pi}} \int_{\epsilon\sigma}^{\infty} Exp\left(\frac{-(\Delta-\mu)^2}{2\sigma^2}\right) d\Delta \quad (14)$$

Where ;  $\epsilon_1, \epsilon_2$  and  $\epsilon$  are fraction numbers .

By using eq.( 12), the allowable limits of drift and those due to the inertia forces due the motion of the roofs can be evaluated .Now by making use of equations (13 and 14) the probability of the building vibrates in safe or dangerous conditions can be found .The results are summarized in table (4)

**Table(4) :** Probabilities of safe and dangerous in the building

Story	$\Delta e$	$\Delta_{min}-\Delta_{max}$	Probabi lity In safe	Probabilit y In failure
1	0.04 09	0.03-0.06	13.74 - 7.35%	86.26% - 92.65
2	0.05 60	0.03-0.06	8.7% - 1.67%	91.3%- 98.33%

#### 4- Conclusions

In the present work a general random vibration is employed to investigate the effect of base acceleration due to earthquake Filtered Kanai – Tajimi power spectrum density regression model is used for earthquake representation .The model is applied on a sample building of two-story assumed at clay conditions in baghdad .

From discussion of the results the following conclusions can be stated ;

- 1- Random vibration analysis is indeterministic in which it can predict the probability of safty rather than the vibration response in time domain .
- 2- The standered diveation of the acceleration response of the first and second story are 69.56 m/s<sup>2</sup> and 95.2836 m/s<sup>2</sup> ,respectively .The normal distribution of the acceleration response of the second story is wider than the first.
- 3- The probability that the building can be safe ia within 13.74 -7.35% for the first story while this reduces to only 8.7% - 1.67% as it compared with the International Building Code 2015
- 4- In general the building is in high risk of failure due to earthquake .

#### Nomenclature

- A Cross -section area
- C Damping ,N.s/m
- E Modulus of Elasticity, N/m<sup>2</sup>
- g Gravitational acceleration m/s<sup>2</sup>
- Ig Moment of inertia ,m<sup>4</sup>
- h Wall height ,m
- H( $\omega$ ) Transfer function
- K Stiffness, s N/m
- m Mass kg
- R<sub>f</sub> Auto correlation function
- S Power spectrum density (PSD)
- S<sub>o</sub> White noise PSD
- S<sub>KT</sub> Flitered Kanai –Tajimi Spetrum
- t Time, s
- x Coordinate
- $\omega_n$  Natural frequency ,r/s
- $\rho$  Density ,kg/m<sup>3</sup>
- $\tau$  Time period ,s
- $\xi$  Damping ratio
- $\Delta$  Drift ratio
- $\mu$  Arithmetic mean
- $\sigma$  Standard deviation
- $\epsilon$  Fraction of standard deviation

#### References

- [1] Åke Fagereng, Virginia G. Toy, Julie V. Rowland ,” Geology of the Earthquake Source: A Volume in Honour of Rick Sibson “, London,2011
- [2] Meifeng Cai, Jin'an Wang ,”Boundaries Of Rock Mechanics: Recent Advances and Challenges” ,ISRM,2008
- [3] USGS Information On Earthquake Hazards and Preparedness: [http:// quake.wr.usgs.gov/hazprep /](http://quake.wr.usgs.gov/hazprep/)
- [4] ]Renolds M.Jon ,”Prediction Of Random Vibration Using Spectral Methods”, PhD thesis 2003
- [5] Quanwang Li,Bruce R. Ellingwood ,”Performance Evaluation And Damage Assessment of Steel Frame Buildings Under Main Shock–Aftershock Earthquake Sequences” , 2007
- [6] Satoshi Matsuda ,”A Regression Model for Estimating Power Spectral Density Function of Ground Acceleration “, The 14<sup>th</sup> World Conference on Earthquake Engineering,, 2008,
- [7] Spilios D. Fassois, Luis David Avendaño Valencia, “Non-Stationary Random Vibration Parametric Modelling and Identification:Methods And Applications” ,SMSA 2009
- [8] Saad Z. Jassim, Jeremy C. Goff ,”Geology of Iraq “, edited by,CZECH Republic,2006
- [9] S.T. De la Cruz, M.A. Rodríguez & V. Hernández ,”Using Spring-Mass Models to Determine the Dynamic Response of Two-Story Buildings Subjected to Lateral Loads” ,

Autonomous University of Ciudad Juárez,  
Ciudad Juárez, Chihuahua, México, WCEE ,  
2012

[10] Richard Worth ,The San Francisco  
Earthquake NewYork 2005

[11] William T.Thomson, “Theory of Vibration  
With Application” ,5 ed ,Newyork 2005

[12] Saad F. A. Al-Wakeel\*, Dr. Mohammed Y.  
Fattah Dr. Hussein H. Karim :Dynamic Analysis  
of Foundations on Saturated Clay Using an  
Energy Absorbing Layer” , Eng. & Tech. Journal,  
Vol.29, No.11, 2011

[13]D.Guida1,F.Nilveti1,C.M.Pappalardo1,Mass,  
Stiffness And Damping Identification of A Two-  
Story Building Model ,3rd ECCOMAS Thematic  
Conference on computational Methods in  
Structural Dynamics and Earthquake Engineering  
M. Papadrakakis, M. Fragiadakis, V. Plevris  
(eds.) Corfu, Greece, 25-28 May 2011

[14] International Code Council, International  
Building Code 2015 (IBC),

## دراسة حالة لحساب الاستجابة للاهتزاز العشوائي لبناية ذات طابقين معرضة للهزة الارضية

صلاح الدين محمد رشيد  
قسم الهندسة المدنية  
جامعة صلاح الدين

أ.م.د.محمود رشيد اسماعيل  
قسم هندسة الاطراف والمساند  
الصناعية  
جامعة النهريين

أ.د.محسن جبر جويج  
قسم هندسة الاطراف والمساند  
الصناعية  
جامعة النهريين

### الخلاصة

تم في هذا العمل البحث والتحليل في الاستجابة الديناميكية لبناية ذات طابقين والمعرضة للزلازل. تم تحليل موديل لحالة الاهتزاز العشوائي لدرجتين من الحرية لمنظومة الكتلة-نابض - مخمد . تم تمثيل التعجيل العشوائي المسلط على قاعدة البناية وفقا للنموذج الذي اقترحه Kanai –Tajimi بدلالة التوزيع الطيفي لطاقة الاهتزاز (PSD). تم ايجاد دالة الخواص الديناميكية بين الأرض والأسطح على افتراض حالة الاهتزاز العرضي . تم البحث في الاهتزاز لنموذج بناية مؤلفة من طابقين مبنية من الخرسانة المسلحة حيث تم حساب الكتلة المكافئة والجساءة والتخميد حسب الكود ACI 318-11 ومنه تم حساب التردد الطبيعي واشكال الطور ودالة الخواص ومن ثم تم ايجاد طيف التعجيل لسطحي البناية ومنه تم ايجاد الانحراف المعياري . واخيرا تم حساب الميل في الجدران و مقارنة مع الحد المسموح حسب ما أوصت به المواصفة IBC 2015. لقد بينت النتائج أن احتمال الامان للطابق الاول هو ما بين (13.74 - 7.35)٪ و (7.8 حتي 67.1)٪ للطابق الثاني .