



# Investigate Air Well Turbines Performance for Power Generation by Tidal Waves in River.

Elaff F. Sharif<sup>1</sup>, Mahmoud Sh. Mahmoud<sup>2\*</sup>, Abdullah A. K. AL-Maskari<sup>3</sup>

## Authors affiliations:

1) Dept. of Mechanical Eng.,  
College of Engineering, Al-  
Nahrain University, Baghdad-  
Iraq.  
[st.elaff.f.sharif@ced.nahrainuniv.edu.iq](mailto:st.elaff.f.sharif@ced.nahrainuniv.edu.iq)

2\*) Dept. of Mechanical Eng.,  
College of Engineering, Al-  
Nahrain University, Baghdad-  
Iraq.  
[mahmoud.s.mahmoud@nahrainuniv.edu.iq](mailto:mahmoud.s.mahmoud@nahrainuniv.edu.iq)

3) University of Technology and  
Applied Science - UTAS – Ibra,  
College of Engineering &  
Technology, Sultanate of Oman  
[Abdullah.a.k.almaskari@utas.edu.om](mailto:Abdullah.a.k.almaskari@utas.edu.om)

## Paper History:

Received: 17<sup>th</sup> Dec. 2022

Revised: 6<sup>th</sup> Feb. 2023

Accepted: 23<sup>rd</sup> June 2023

## Abstract

The phenomenon of climate change resulting from the increase of global warming has become one of the main problems facing the world. Where researchers and specialists have worked for many years to find a solution that reduces this phenomenon and limits its risks. It is likely that clean energy is an alternative to fossil fuel sources, which are the main source of global warming. One of the clean energy sources is ocean wave energy, which is a huge and untapped energy source, despite the possibility of extracting large energy from waves. This paper focuses on the study of deep-sea turbines and their results. A study was conducted on the capture chamber. Where this paper presents an experimental model of a water tank with certain dimensions in the university laboratories to describe the dynamic behavior of the capture chamber. The Froude number scale was used to model the dimensions and depth of the water as well as the wave properties. Through experimental work and its results show, and it was found that the power generated by the motion of the wave strength is related to the height and frequency of the wave.

**Keywords:** Wave energy, Air turbine, performance, power generation.

التحقق من أداء توربينات الآبار الهوائية لتوليد الطاقة عن طريق أمواج المد والجزر في الأنهار

إيلاف فلاح شريف، محمود شاكر محمود، عبد الله عظيم خالد المسكري

## الخلاصة:

أصبحت ظاهرة التغير المناخي الناتجة عن زيادة الاحتباس الحراري إحدى المشكلات الرئيسية التي تواجه العالم. حيث عمل الباحثون والمتخصصون لسنوات عديدة لإيجاد حل يقلل من هذه الظاهرة ويحد من مخاطرها. من المحتمل أن تكون الطاقة النظيفة بديلاً لمصادر الوقود الأحفوري، والتي تعد المصدر الرئيسي للاحتباس الحراري العالمي. من مصادر الطاقة النظيفة طاقة أمواج المحيط، وهي مصدر طاقة ضخم وغير مستغل، على الرغم من إمكانية استخلاص طاقة كبيرة من الأمواج. تركز هذه الورقة على دراسة توربينات أعماق البحار ونتائجها. أجريت دراسة على غرفة الالتقاط. حيث يقدم هذا البحث نموذجاً تجريبياً لحزان مياه بأبعاد معينة في مختبرات الجامعة لوصف السلوك الديناميكي لغرفة الالتقاط. تم استخدام مقياس رقم Froude لنمذجة أبعاد وعمق المياه بالإضافة إلى خصائص الموجة. من خلال العمل التجريبي ونتائجه، وجد أن الطاقة الناتجة من حركة الموجة مرتبطة بارتفاع الموجة وترددتها.

## 1. Introduction

Climate pollution and demand for electricity, in addition to high diesel price, are among the main reasons that encourage the use of renewable energies [1]. It has been proven that one third of the world's

population does not have access to electricity but has the means to get it [2].

Renewable energy of all kinds provides clean and effective energy by reducing greenhouse gas emissions and providing job opportunities in addition to economic development [1]. Among the forms of



renewable energy are the seas and oceans, which store energy in the form of thermal energy, tidal energy, and others. The possibility of using the energy of ocean waves can cover a large part of the electricity consumption [3]. The concept of collecting and using ocean energy was not a new as the (WEC) wave transducer was used in 1799 and was patented [4], and the first practical form of using wave energy was by Y Masuda when he used ocean waves to power navigation buoys [5]. Ocean wave energy has the second largest potential among all ocean renewable energy sources [6][7], and despite differing opinions, some studies have determined the amount that can be exploited as 10 – 20% of the total potential. [8]

## 2. Technology OWC:

OWC is a type of (WEC) [9] transducer which is one of the ways that are used to extract energy from ocean waves [10]. These systems are one of the solutions to current problems of energy and an alternative to the use of fossil fuels [11]. Mutriku station is the only commercially powered OWC station in the world now. This system consists of two main components: a concrete chamber and a turbine generator set that converts wave energy into electricity [12]. A partially submerged structure is constructed, where the trapping of air above the surface of the free air depends on the submerged part under the surface of the water, the air moves within the inner surface according to the oscillating movement of water that drives the turbines placed across it. The original design of the flow chamber could be detrimental to the operation of the turbine due to water mist from the jet air on the water-free surface [3]. It has been suggested that the air passage be designed to be as smooth and short as possible to prevent poor flow distribution that seriously reduces turbine efficiency [13]. A horizontal baffle plate was used to drain air from the turbine, and its effectiveness has been proven. These systems are affected by wave direction as well as water depth.

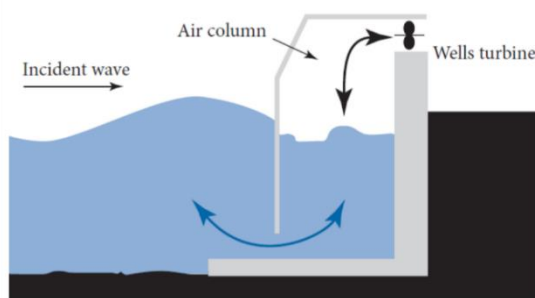

Figure (1): Oscillating column of water [14].

Profile of wave ( $\eta$ ) and ( $H$ ) water height may be given by

$$\eta = \frac{H}{2} \cos(kx - \omega t + B) \quad (1)$$

Where vector of wave  $k = 2\pi / \lambda$ ,  $\omega = 2\pi / T$ . Denotes the depth of the water  $d$  and the horizontal wave  $x$ :

$$\omega^2 = kg \tanh(kd) \quad (2)$$

$$\lambda = T^2 g / 2\pi \tanh(kd) \quad (3)$$

Since the 1970s, the free inner surface was considered as a weightless solid piston to determine the hydrodynamic pressure in OWC, which is a simple model. The equation of motion, as did Sykes, has been used to describe the behavior of OWC [15], as the pressure on the free surface is assumed to be zero and pressure constant  $P$  across  $S$  at  $z=-L$  :

$$\rho S(L + \eta_{owc})\eta_{owc} + \rho S g \eta_{owc} S P_{owc} \quad (4)$$

Where  $\rho$  is density,  $\eta_{owc}(t)$  and  $P_{owc}(t)$  are the height of the free surface of the water column and dynamic pressure in OWC. These models ignore the spatial differences of the inner free surface and therefore will only be appropriate when the diffraction pressure is zero across the horizontal plane.

Pressure distribution theory which was formulated by Falcao [16] and generalized by Evans [17], and is the second method for evaluating hydrodynamic behavior in OWC. This theory allows for an accurate description of the free inner surface. Some equations that govern the behavior of OWC are mentioned which are still in the potential flow framework:

### (1) Equation of air mass conservation:

Using the Sarmiento and method of Falcao (1985) [18], which postulates the theory of equal evolution. This theory assumes equal and following expression is used for the evolution of the air volume in chamber by Chatry [19]:

$$q^t(t) = \frac{-dV(t)}{dt} - \frac{V_0}{\gamma p_a} \frac{dp(t)}{dt} \quad (5)$$

Where:  $V_0$  air volume at the free surface at rest in the chamber,  $dV(t)/dt$  is the hydrodynamic flux of volume,  $V_0 / \gamma p_a$  Air Compression Effect ( $p_a$ : atmospheric pressure,  $\gamma$ : constant specific heat volume and pressure).

### (2) Equation of governing for devices OWC:

Hydrodynamic volume flow using the above decomposition into a problem of diffraction radiation, and this equation allows modeling of the behavior of OWC:

$$q^t(t) = q^D(t) + q^R(t) - \frac{V_0}{\gamma p_a} \frac{dp(t)}{dt} \quad (6)$$

A significant improvement in OWC performance can be achieved by improving turbine rotational speed control as well as improving rotor diameter as demonstrated by Falcao [20].

## 3. Calculating Wave Energy Using an Oscillating Water Column (OWC):

There are many things to know before calculating the energy of wave in the model, including the ocean energy of wave potential, chamber dimension, gravity of earth, and the specific gravity of the wind [14]. To calculating the wave energy, the following equation is used:

$$E = (P_2 - P_0) A_2 V_2 \quad (7)$$

Where  $E$  is power of OWC,  $P_2$  is orifice air pressure,  $P_0$  is air pressure outside the system,  $A_2$  is orifice column area,  $V_2$  is air flow speed around the orifice.



To get parameters in the above equation we use the following equations:

$$V_1 = \frac{\omega}{2} H \sin(\omega t) \quad (8)$$

$$V_2 = \frac{A_1}{A_2} V_1 \quad (9)$$

$$P_2 = P_0 + \rho \left( \frac{A_1}{A_2} \right) \frac{d\phi}{dt} \rho \frac{Q_2}{A_2} (V_2 - V_1) \quad (10)$$

To calculate electrical power that can be generated from the energy wave, use the following equation:

$$P_{owc} = \frac{\rho g^2}{64\pi} H^2 T w \eta_{owc} \quad (11)$$

Where  $P_{owc}$  is electrical power,  $H$  is wave height,  $T$  is wave period,  $w$  is chamber width.

The total efficiency of an (OWC) is the product of the sum of the efficiencies of the generator, chamber, and turbine used in the (OWC) system. According to several studies, the overall efficiency of the (OWC) system range from 0-20% of the total potential energy produced by the waves, depend on the height of wave and its period [21].

$$\eta_{owc} = \eta_t \eta_p \eta_g \quad (12)$$

Where  $\eta_{owc}$  is total efficiency of OWC,  $\eta_g$  is efficiency of generator,  $\eta_p$  is efficiency of chamber,  $\eta_t$  is efficiency of turbine.

#### 4. Turbines:

OWC plants must be equipped with air turbines such as (Wells turbines, radial turbines, Savonius turbine, and impulse turbines) [22]. Air turbine conventional is used to convert secondary part of the energy into OWC wave transducer, but in a large energy of wave, such systems cannot be adopted because the valve becomes large. If self-correcting air turbines are used, no correction valve is required to convert wave energy.

Impulse turbines with steering rotors actively controlled using a hydraulic actuator have been proposed and selected [23]. The authors have also proposed a radial turbine with actively controlled steering vanes to convert energy of wave [24] but according to the latest research, the efficiency of the turbine is not good [25].

The features of air turbine for converting energy of waves were studied through numerical simulation and offshore experiment under the condition of irregular flow and it has been found that turbine impulse type could outperform well turbine [22]. The performance of a unidirectional impulse turbine has been experimentally under steady flow conditions using a piston with a wind tunnel [26]. The unidirectional turbine has shown good efficiency over a wide range [27]. The authors have suggest with twin turbines are using new topology that promises to produce 50% of the wave to wire efficiency of the OWC [28].

OWC stations must be equipped with self-correcting turbines which can maintain the same direction of rotation regardless of the direction of the air. Among these turbines, well turbines are the most common and over many years, designs have been developed to eliminate their flaws and make them better than conventional turbines such as reducing noise, and increase efficiency [29].

With many research and experiments conducted to improve the efficiency regarding the turbines used in OWC, it was found that the thrust turbines are more suitable for sudden rise in wind power and their efficiency is up to 75% [30]. In power plants, two types of turbines are used across Europe, Japan, Korea, and India are well turbines and impulse turbines [31][28].

#### 5. Generators:

Generators are devices that convert mechanical energy into electrical energy, and generators in general can give AC or DC. There are several factors that determine the choice of generator, such as the speed of the prime mover, output power, and operating range. One of the types of generators are synchronous generators that operate at a constant speed with permanent magnet system [1]. Its advantages include high efficiency due to direct drive permanent magnet, It has brushes which makes maintenance low costs, low noise and high energy density as well as at variable speed provide constant frequency and voltage [32].

The other types of generators are induction generators which are the most common in independent power generation systems. It is one of the preferred generators to produce electricity on a small scale due to its simplicity, its ability to protect and its small size [33], as this type does not require an external DC source [34].

One of the most effective and simplest laws of control is the law derived from simple physical arguments. If the inertia is zero and the goal is to increase the efficiency of turbine, the turbines must be operated at the best point of power and efficiency of the turbine must be proportional [35]:

$$P_{turb}(\Psi_{bep}, \Omega) = \rho D^5 f(u \Psi_b e_p) \Omega^3 \quad (13)$$

The power of generator control should follow the relation:

$$P_{ctrl} = a_{bep} \Omega^3 \quad (14)$$

The coupling between the OWC and aerodynamics of turbine is considered in case the inertia is large, as in the following equation [36]:

$$P_{ctrl} = a_{bep} \Omega^b \quad (15)$$

A variable frequency drive is used to connect the electric generators to the grid, and the drive is controlled in torque mode and depends on the following relationship:

$$T_{ctrl}^{lim} = \min \left[ \Omega^{b-1}, \frac{P}{\Omega}, T_{gen} \right] \quad (16)$$

The matrix transformer topology achieves direct conversion AC /AC and has not a DC link feature. Whereas a topology that includes intermediate DC conversion and no voltage is a complex system and is not used because of this. The lack of DC link of electrolytic capacitor can be a good feature in term of life [9]. The multi-level array transformer motors matrix have been investigated [37] [38].

During the past twenty years, we note the development and technical change in generators, as



the technological development of microprocessors increases the performance of multiple functions [9].

A method used in the 1990s and 2000s is considered a good method, which is to use bridge rectifiers along with generators [39] [40]. In 1997, one of the most important advantages of the PICO OWC plant is the use of a variable speed electric generator. One of the main tasks of the project is the development of unconventional control equipment and the development of power electronics. A mains transformer current source inverter (CSI), which is the approved power transformer for this system, is used.

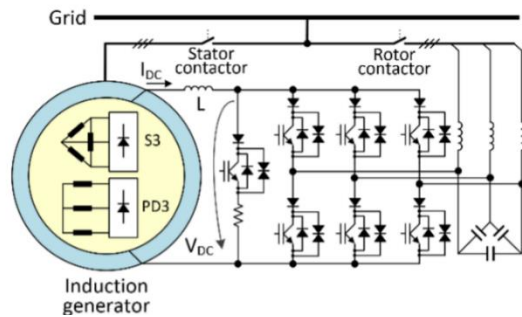

Figure (2): Diagram of the PTO electrical for the PICO OWC [9].

## 6. Control law:

The latest control systems in OWC consist of two systems, the wave transducer control and transducer control, the first control the speed of rotation of the turbine and the flow of air [41], and the second control the electrical variable as active power.

The electronics of power unit controls the WEC turbine's generator and can increase control strategies as the OWC's mechanical and electrical parts become more complex, i.e., implementation of the strategy affects the efficiency of power conversion as well as requirements such as durability, capacity, maintenance, and cost.

The maximum power position can be tracked depending on the rotational speed and is one of the reliable solution with a preprogrammed feature obtained from the model of turbines, such as MPPT method based on the torque reference [42].

The wind flow is bilateral in the case of single chamber of OWC, and this requires the selection of suitable turbines technology, i.e., the well turbine. The stall phenomenon occurs when the ratio between the blade tip speed and velocity of wind exceeds a certain limit. Therefore, it is necessary that the control element be designed to avoid this phenomenon [43], the air flow coefficient should be within certain limits.

In multi-chamber systems of OWC, unidirectional turbine is used, the control problems are similar to the open field wind power conversion system [44].

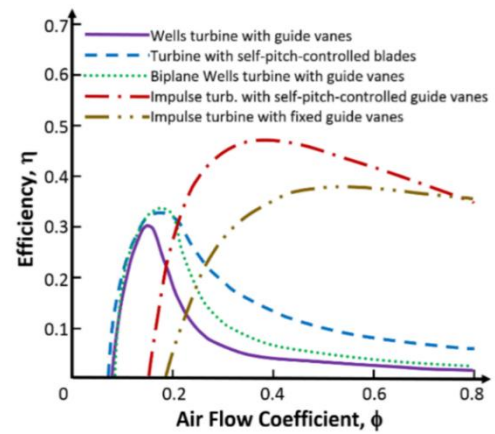

Figure (3): Efficiency of self-correcting turbines [45].

## 7. OWC chamber:

The case study consists of a watercourse with a depth of 50 cm, a width of 100 cm, and a length of 300 cm, and it is open to the atmosphere. The test required us to make waves at specific speeds (5 speeds have been determined), the primary four speeds have been simulating ordinary sea situations and the 5th velocity became simulating the kingdom of turbulence in sea water. Shown fig (4), (5).

Based on previous studies, this type of turbine and its dimensions were chosen, in addition to the dimensions being chosen to suit the water basin. The Wells turbine adopted for the experiments. Wells turbine tested in detail in case of casing diameter  $D_w = 200$  mm is as follows. The blade Profile NACA0021, number of blades 6 (symmetric). Shown fig (6).

The basin is isolated from the vibrations that could occur as a result of the wave maker's work by installing the wave maker's motor on a stand, far enough from the basin.

The results of previous experiments (Teixeira), a similar case, showed that a wave height of one meter does not cause wave refraction, and that the turbulence effects using model were lower at free surface height outside and inside the water chamber. This means that turbulence modeling is not used in this case because the effect of turbulence on hydrodynamics is not significant.

Verification demonstration the accuracy of the model to represent phenomena is an important step in numerical simulation. The First regular wave digital simplified external OWC device and first Falcao code validation for OWC devices by Paixão Conde. In this work two things were considered for the chamber:

1. The chamber is open to the atmosphere.
2. The well turbine is placed in the upper part of the chamber.

By comparing the numerical results with other numerical results obtained from the Fluent model and with the experimental results, the authors showed the accuracy of the Fluinco model. In recent research, Teixeira (2013) validated Fluinco model for OWC devices by comparing results. The authors used pneumatic power to evaluate the efficiency of



the device, which is the force a turbine uses to generate mechanical power. In the case of this study, due to the standard difficulties in turbine modeling, a simple air vent was used to provide a representative analogy with the pressure drop associated with the airflow passing through the turbine.

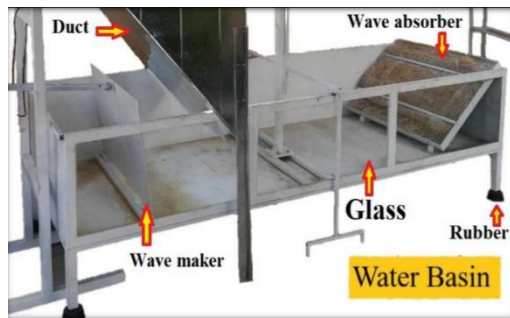

Figure (4): Shows water basin.

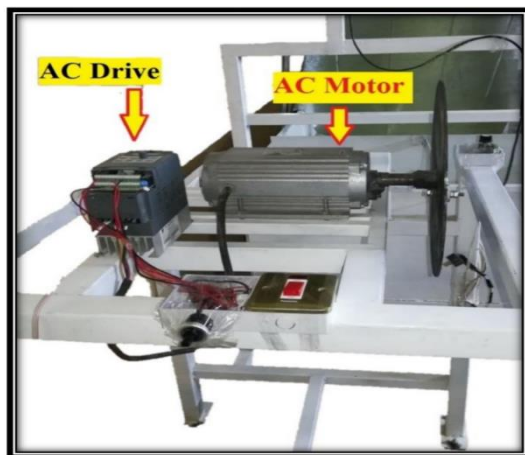

Figure (5): Schematic showing the connection of the parts of the water basin experiment equipment.

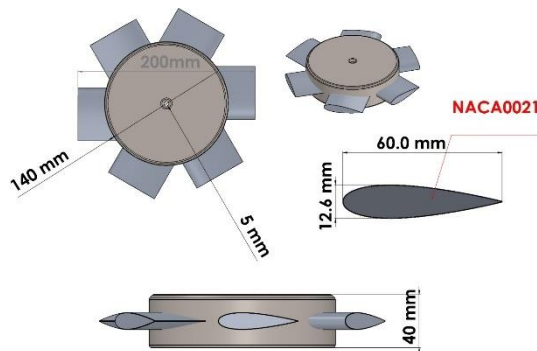

Figure (6): Geometric parameters of the Well turbine.

## 8. Results

Results of the experimental work are discussed in this chapter, which includes the amount of power that can be obtained from the movement of waves within the specified characteristics.

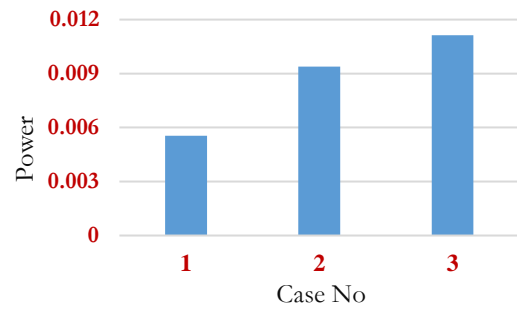

Figure (7): The comparative of the amount of power for three cases.

Table (1): Values of the Results of the experimental work.

Case No	H (cm)	T (S)	$\Lambda$ (cm)	$f$ (Hz)	I (A)	V (V)	P (Watt)
1.	1.2	0.5	39	2.0	0.0396	0.140	0.005544
2.	1.9	0.6	53	1.66	0.0435	0.216	0.009396
3.	2.85	0.8	76	1.25	0.0483	0.231	0.011342

Notice that the amount of output power and wavelength increase has an increasing period.

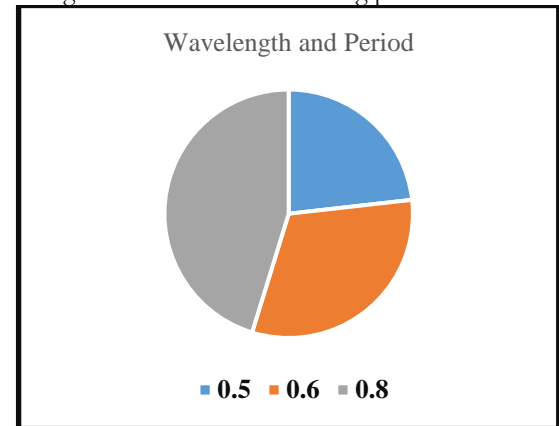

Figure (8): The comparative of the amount wavelength at different period.

## 9. Conclusions:

In this paper, the power ratio of the OWC device has been verified by experimental work, which is based on the Navier-Stokes equations as well as air-water dynamics, considering the effect of wells turbines and control of air pressure inside the chamber.

The power output was taken for more than one wavelength and different wave heights. This study showed, when taking different speeds, the importance of rotational speed in turbine performance. Through experimental work and its results show, and it was found that the power generated by the motion of the wave is related to the height and frequency of the waves. In addition, the amount of power obtained from the rotation of the turbine in the air chamber depends on the height and wavelength of the water.

## 10. References:

- [1] H. J. Vermaak, K. Kusakana, and S. P. Koko, "Status of micro-hydrokinetic river technology in



- rural applications: A review of literature,” *Renew. Sustain. Energy Rev.*, vol. 29, pp. 625–633, 2014.
- [2] D. J. Bertsch, “Hydrokinetic energy: trying to navigate the energy and wave law framework to develop new renewable energy technology,” *Accessed June*, vol. 8, 2012.
- [3] J. M. P. Conde and L. M. C. Gato, “Numerical study of the air-flow in an oscillating water column wave energy converter,” *Renew. energy*, vol. 33, no. 12, pp. 2637–2644, 2008.
- [4] D. Ross, *Power from the Waves*. Oxford University Press, USA, 1995.
- [5] Y. Masuda, “An experience of wave power generator through tests and improvement,” in *Hydrodynamics of ocean wave-energy utilization*, Springer, 1986, pp. 445–452.
- [6] T. W. Thorpe, “A brief review of wave energy,” 1999.
- [7] A. Ilyas, S. A. R. Kashif, M. A. Saqib, and M. M. Asad, “Wave electrical energy systems: Implementation, challenges and environmental issues,” *Renew. Sustain. Energy Rev.*, vol. 40, pp. 260–268, 2014.
- [8] J. Cruz, *Ocean wave energy: current status and future perspectives*. Springer Science & Business Media, 2007.
- [9] N. Delmonte, D. Barater, F. Giuliani, P. Cova, and G. Buticchi, “Review of oscillating water column converters,” *IEEE Trans. Ind. Appl.*, vol. 52, no. 2, pp. 1698–1710, 2015.
- [10] T. O. Aderinto, F. Haces-Fernandez, and H. Li, “Design and Potential Application of Small Scale Wave Energy Converter,” in *ASME International Mechanical Engineering Congress and Exposition*, 2017, vol. 58417, p. V006T08A084.
- [11] A. J. Garrido *et al.*, “Mathematical modeling of oscillating water columns wave-structure interaction in ocean energy plants,” *Math. Probl. Eng.*, vol. 2015, 2015.
- [12] A. El Barakaz and A. El Marjani, “Water Oscillation Modelling Inside OWC Chamber for Wave Energy Conversion,” *Int. J. Renew. Energy Res.*, vol. 11, no. 2, pp. 826–841, 2021.
- [13] M. Folley, R. Curran, and T. Whittaker, “Comparison of LIMPET contra-rotating wells turbine with theoretical and model test predictions,” *Ocean Eng.*, vol. 33, no. 8–9, pp. 1056–1069, 2006.
- [14] E. Affandi and L. A. Anzar, “Study on Wave Energy Conversion by Using Oscillating Water Column in Alindau Waters,” in *MATEC Web of Conferences*, 2020, vol. 331, p. 3001.
- [15] R. K. Sykes, A. W. Lewis, and G. P. Thomas, “Predicting hydrodynamic pressure in fixed and floating owc using a piston model,” 2011.
- [16] A. F. de O. Falcão and A. Sarmento, “Wave generation by a periodic surface pressure and its application in wave-energy extraction,” 1980.
- [17] D. V. Evans, “Wave-power absorption by systems of oscillating surface pressure distributions,” *J. Fluid Mech.*, vol. 114, pp. 481–499, 1982.
- [18] A. J. N. A. Sarmento and A. F. de O. Falcão, “Wave generation by an oscillating surface-pressure and its application in wave-energy extraction,” *J. Fluid Mech.*, vol. 150, pp. 467–485, 1985.
- [19] G. Chatry, “Développement et simulation d’une méthode de régulation auto-adaptative pour l’absorption dynamique des ondes de gravité.” Nantes, 2032.
- [20] A. F. De O Falcão and R. J. A. Rodrigues, “Stochastic modelling of OWC wave power plant performance,” *Appl. Ocean Res.*, vol. 24, no. 2, pp. 59–71, 2002.
- [21] T. Aderinto and H. Li, “Review on power performance and efficiency of wave energy converters,” *Energies*, vol. 12, no. 22, p. 4329, 2019.
- [22] M. Takao and T. Setoguchi, “Air turbines for wave energy conversion,” *Int. J. Rotating Mach.*, vol. 2012, 2012.
- [23] F. Thiebaut *et al.*, “Testing of a floating OWC device with movable guide vane impulse turbine power take-off,” 2011.
- [24] M. Takao, Y. Fujioka, and T. Setoguchi, “Effect of pitch-controlled guide vanes on the performance of a radial turbine for wave energy conversion,” *Ocean Eng.*, vol. 32, no. 17–18, pp. 2079–2087, 2005.
- [25] T. Setoguchi, S. Santhakumar, M. Takao, T. H. Kim, and K. Kaneko, “A performance study of a radial turbine for wave energy conversion,” *Proc. Inst. Mech. Eng. Part A J. Power Energy*, vol. 216, no. 1, pp. 15–22, 2002.
- [26] M. Takao, A. Takami, S. Okuhara, and T. Setoguchi, “A twin unidirectional impulse turbine for wave energy conversion,” *J. Therm. Sci.*, vol. 20, no. 5, pp. 394–397, 2011.
- [27] M. Takao, T. Setoguchi, K. Kaneko, T. H. Kim, H. Maeda, and M. Inoue, “Impulse turbine for wave power conversion with air flow rectification system,” *Int. J. offshore polar Eng.*, vol. 12, no. 02, 2002.
- [28] V. Jayashankar *et al.*, “A twin unidirectional impulse turbine topology for OWC based wave energy plants,” *Renew. energy*, vol. 34, no. 3, pp. 692–698, 2009.
- [29] T. Setoguchi and M. Takao, “Current status of self rectifying air turbines for wave energy conversion,” *Energy Convers. Manag.*, vol. 47, no. 15–16, pp. 2382–2396, 2006.
- [30] S. Natanzi, J. A. Teixeira, and G. Laird, “A novel high-efficiency impulse turbine for use in oscillating water column devices,” 2011.
- [31] S. Raghunathan, C. P. Tan, and O. O. Ombaka, “Performance of the Wells self-rectifying air turbine,” *Aeronaut. J.*, vol. 89, no. 890, pp. 369–379, 1985.
- [32] H. Zhou, “Maximum power point tracking control of hydrokinetic turbine and low-speed high-thrust permanent magnet generator design,” Missouri Univ of Science And Technology Rolla, 2012.
- [33] L. G. Scherer and R. F. de Camargo, “Control of micro hydro power stations using nonlinear model of hydraulic turbine applied on microgrid



- systems,” in *XI Brazilian Power Electronics Conference*, 2011, pp. 812–818.
- [34] B. A. Singh, S. B. Singh, M. Singh, R. Dixit, N. Mittal, and A. Baranwal, “Stand Alone power generation by  $3\phi$  asynchronous generator: a comprehensive survey,” *Int. J. Rev. Comput.*, vol. 10, pp. 36–51, 2012.
- [35] J. C. C. Henriques, J. C. C. Portillo, W. Sheng, L. M. C. Gato, and A. F. de O. Falcão, “Dynamics and control of air turbines in oscillating-water-column wave energy converters: Analyses and case study,” *Renew. Sustain. Energy Rev.*, vol. 112, pp. 571–589, 2019.
- [36] R. Waters, J. Engström, J. Isberg, and M. Leijon, “Wave climate off the Swedish west coast,” *Renew. energy*, vol. 34, no. 6, pp. 1600–1606, 2009.
- [37] Q. Jianglei, X. Lie, L. Wang, Q. Lin, and L. Yongdong, “The modulation of common mode voltage suppression for a three-level matrix converter,” in *2016 IEEE International Conference on Aircraft Utility Systems (AUS)*, 2016, pp. 533–538.
- [38] S. Khwan-On, L. De Lillo, L. Empringham, P. Wheeler, and C. Gerada, “Fault-tolerant, matrix converter, permanent magnet synchronous motor drive for open-circuit failures,” *IET Electr. power Appl.*, vol. 5, no. 8, pp. 654–667, 2011.
- [39] D. R. Kiran, A. Palani, S. Muthukumar, and V. Jayashankar, “Steady grid power from wave energy,” *IEEE Trans. Energy Convers.*, vol. 22, no. 2, pp. 539–540, 2007.
- [40] G. D. Marques, “Stability study of the slip power recovery generator applied to the sea wave energy extraction,” in *PESC’92 Record. 23rd Annual IEEE Power Electronics Specialists Conference*, 1992, pp. 732–738.
- [41] A. F. de O. Falcão, L. C. Vieira, P. A. P. Justino, and J. André, “By-pass air-valve control of an OWC wave power plant,” *J. Offshore Mech. Arct. Eng.*, vol. 125, no. 3, pp. 205–210, 2003.
- [42] B. Neammanee, K. Krajangpan, S. Sirisumrannukul, and S. Chatratana, “Maximum peak power tracking-based control algorithms with stall regulation for optimal wind energy capture,” *IEEJ Trans. Ind. Appl.*, vol. 128, no. 4, pp. 411–417, 2008.
- [43] M. Amundarain, M. Alberdi, A. J. Garrido, I. Garrido, and J. Maseda, “Wave energy plants: Control strategies for avoiding the stalling behaviour in the Wells turbine,” *Renew. Energy*, vol. 35, no. 12, pp. 2639–2648, 2010.
- [44] N. A. Orlando, M. Liserre, R. A. Mastromauro, and A. Dell’Aquila, “A survey of control issues in PMSG-based small wind-turbine systems,” *IEEE Trans. Ind. Informatics*, vol. 9, no. 3, pp. 1211–1221, 2013.
- [45] T.-H. Kim, M. Takao, T. Setoguchi, K. Kaneko, and M. Inoue, “Performance comparison of turbines for wave power conversion,” *Int. J. Therm. Sci.*, vol. 40, no. 7, pp. 681–689, 2001.